



US 20250233300A1

(19) **United States**

(12) **Patent Application Publication**  
**KOBAYASHI**

(10) **Pub. No.: US 2025/0233300 A1**

(43) **Pub. Date: Jul. 17, 2025**

(54) **ANTENNA AND COMMUNICATION DEVICE**

(30) **Foreign Application Priority Data**

(71) Applicant: **Sony Group Corporation**, Tokyo (JP)

Nov. 2, 2021 (JP) ..... 2021-179245

(72) Inventor: **Tomoo KOBAYASHI**, Tokyo (JP)

**Publication Classification**

(73) Assignee: **Sony Group Corporation**, Tokyo (JP)

(51) **Int. Cl.**  
**H01Q 1/22** (2006.01)

(21) Appl. No.: **18/701,617**

(52) **U.S. Cl.**  
CPC ..... **H01Q 1/22** (2013.01)

(22) PCT Filed: **Sep. 29, 2022**

(57) **ABSTRACT**

(86) PCT No.: **PCT/JP2022/036330**

An antenna includes a wiring portion. The wiring portion, being a conductive portion, is disposed on a substrate, and extends from a proximal end on which the power supply portion is provided to a distal end. The wiring portion has at least a main surface of the distal end exposed.

§ 371 (c)(1),  
(2) Date: **Apr. 16, 2024**

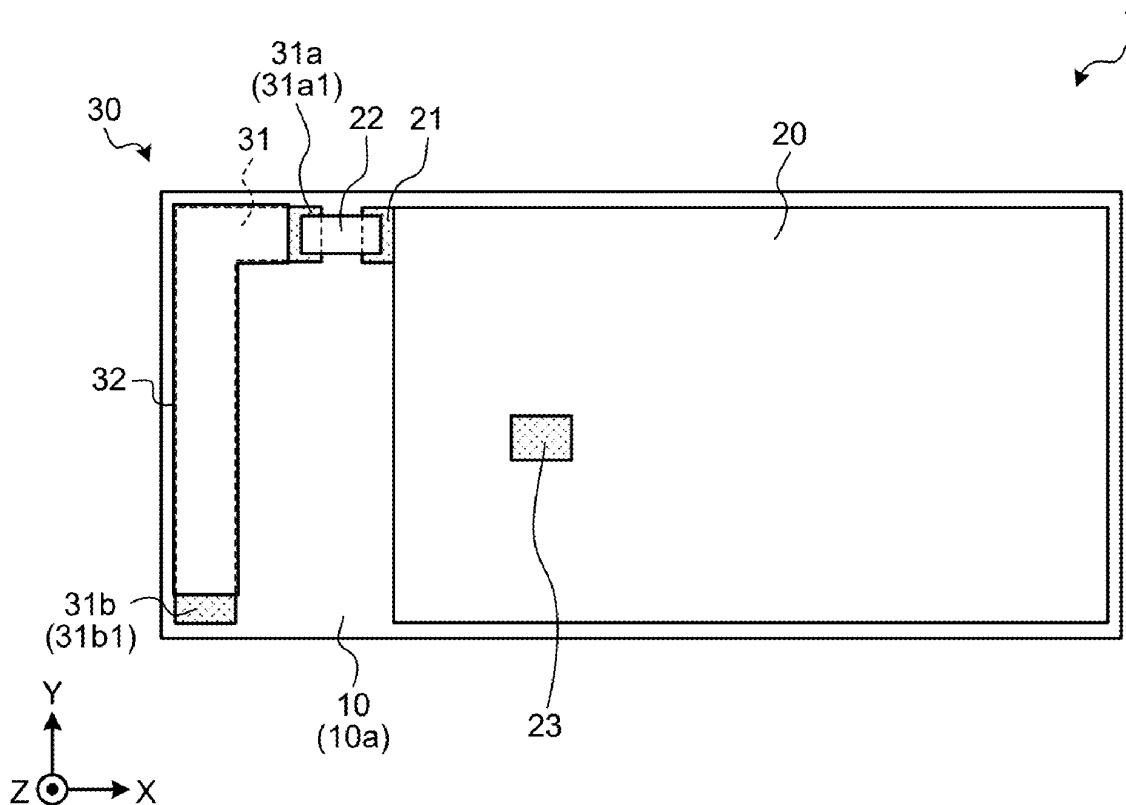



US 20250233310A1

(19) **United States**

(12) **Patent Application Publication**  
**LIN et al.**

(10) **Pub. No.: US 2025/0233310 A1**

(43) **Pub. Date: Jul. 17, 2025**

(54) **ELECTRONIC DEVICE**

*H01Q 3/26* (2006.01)

*H01Q 21/29* (2006.01)

(71) Applicant: **Advanced Semiconductor Engineering, Inc.**, Kaohsiung (TW)

(52) **U.S. Cl.**

CPC ..... *H01Q 9/0414* (2013.01); *H01Q 1/22* (2013.01); *H01Q 21/29* (2013.01); *H01Q 3/26* (2013.01)

(72) Inventors: **Po-An LIN**, Kaohsiung (TW); **Shao-En HSU**, Kaohsiung (TW)

(73) Assignee: **Advanced Semiconductor Engineering, Inc.**, Kaohsiung (TW)

(57) **ABSTRACT**

An electronic device is disclosed. The electronic device includes a first pattern, a second pattern adjacent to the first pattern, and a third pattern disposed between the first pattern and the second pattern. The electronic device also includes a first feeding element and a second feeding element. The first feeding element is spaced apart from the first pattern and the third pattern and configured to electrically couple the first pattern and the third pattern to constitute a first antenna. The second feeding element is configured to electrically couple the second pattern and the third pattern to constitute a second antenna.

(21) Appl. No.: **18/415,637**

(22) Filed: **Jan. 17, 2024**

**Publication Classification**

(51) **Int. Cl.**  
*H01Q 9/04* (2006.01)  
*H01Q 1/22* (2006.01)

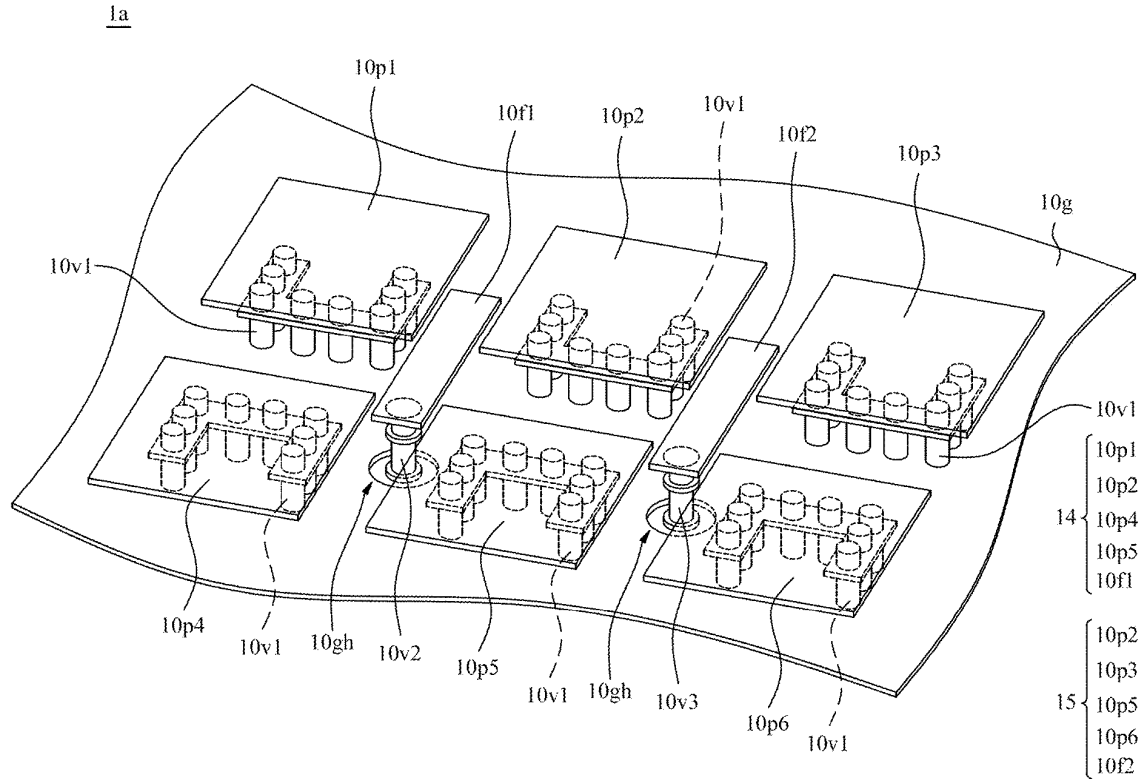



US 20250233313A1

(19) **United States**

(12) **Patent Application Publication**  
**LI**

(10) **Pub. No.: US 2025/0233313 A1**

(43) **Pub. Date: Jul. 17, 2025**

(54) **MOBILE TERMINAL**

**Publication Classification**

(71) Applicant: **BEIJING XIAOMI MOBILE SOFTWARE CO., LTD.**, Beijing (CN)

(51) **Int. Cl.**  
*H01Q 13/18* (2006.01)  
*H01Q 1/22* (2006.01)  
*H01Q 1/24* (2006.01)

(72) Inventor: **Yueliang LI**, Beijing (CN)

(52) **U.S. Cl.**  
CPC ..... *H01Q 13/18* (2013.01); *H01Q 1/2291* (2013.01); *H01Q 1/241* (2013.01)

(73) Assignee: **BEIJING XIAOMI MOBILE SOFTWARE CO., LTD.**, Beijing (CN)

(57) **ABSTRACT**

(21) Appl. No.: **18/374,654**

The present disclosure relates to the field of electronic device technology, and specifically provides a mobile terminal including a housing and an antenna system. The antenna system includes a first low-frequency antenna and a second low-frequency antenna respectively provided close to two opposite sides of the housing, and at least one of the first low-frequency antenna and the second low-frequency antenna is a cavity antenna.

(22) Filed: **Sep. 28, 2023**

(30) **Foreign Application Priority Data**

May 17, 2023 (CN) ..... 202310560965.5

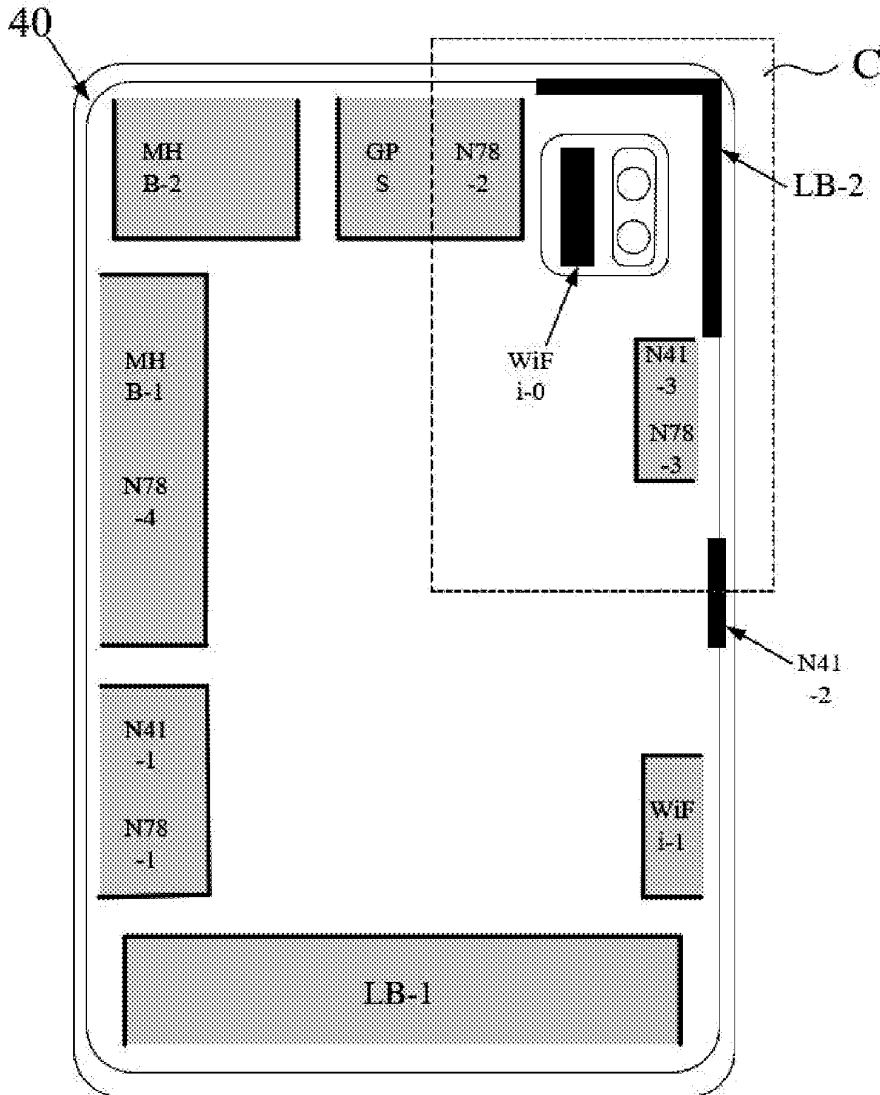



US 20250233315A1

(19) **United States**

(12) **Patent Application Publication**  
**ZHANG et al.**

(10) **Pub. No.: US 2025/0233315 A1**

(43) **Pub. Date: Jul. 17, 2025**

(54) **ANTENNA SYSTEM FOR WIDE ANGLE  
SCANNING ANTENNA ARRAY**

(52) **U.S. Cl.**  
CPC ..... **H01Q 13/18** (2013.01); **H01Q 1/2283**  
(2013.01)

(71) Applicant: **The Antenna Company International  
N.V.**, Eindhoven (NL)

(72) Inventors: **Yingqi ZHANG**, Gothenburg (SE);  
**Stanislav OGURTSOV**, Eindhoven  
(NL); **Vasilii VASILEV**, Veldhoven  
(NL); **Diego CARATELLI**, Eersel (NL)

(57) **ABSTRACT**

The invention relates to an antenna element comprising a dielectric substrate and a multi-layer laminate structure included in the dielectric substrate. The multi-layer laminate structure comprises an impedance matching layer, a resonating cavity with a cross-shaped slot, and a pair of conductive forks, configured and arranged to feed the cross-shaped slot. The invention further relates to an antenna subarray, comprising a dielectric substrate and a multi-layer laminate structure included in the dielectric substrate. The multi-layer laminate structure comprises an impedance matching layer, an array of resonating cavities, each with a cross-shaped slot, and an array of pairs of conductive forks, each pair configured and arranged to feed the cross-shaped slot of a corresponding resonating cavity.

(21) Appl. No.: **19/016,099**

(22) Filed: **Jan. 10, 2025**

**Related U.S. Application Data**

(60) Provisional application No. 63/620,019, filed on Jan. 11, 2024.

**Publication Classification**

(51) **Int. Cl.**  
**H01Q 13/18** (2006.01)  
**H01Q 1/22** (2006.01)

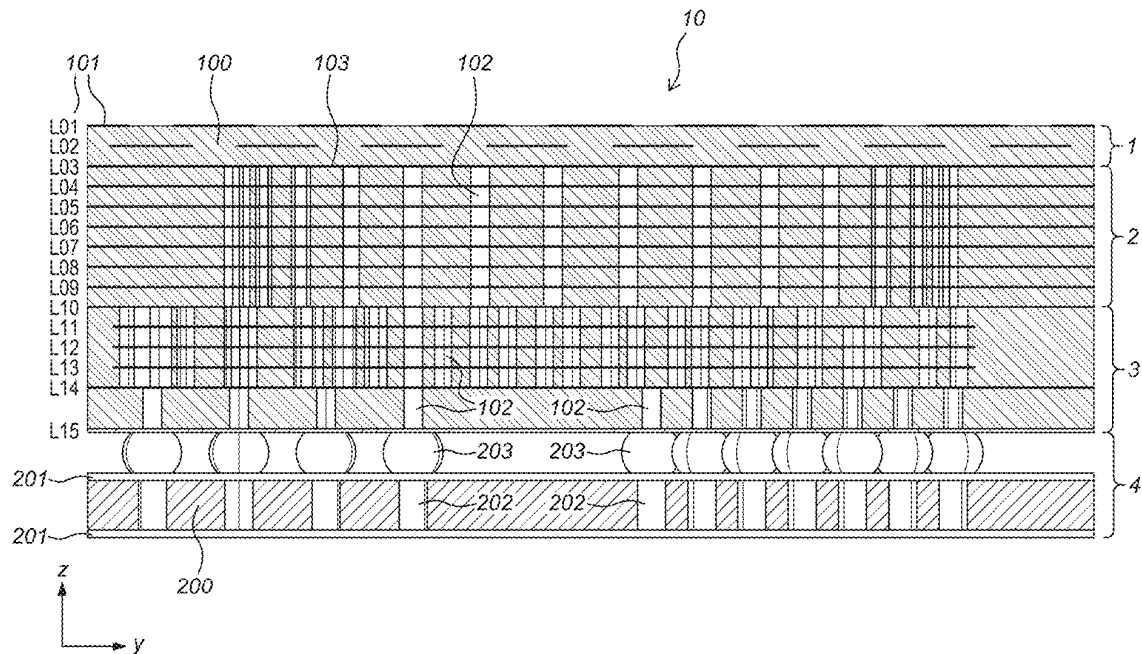



US 20250233320A1

(19) **United States**

(12) **Patent Application Publication**

**Tian et al.**

(10) **Pub. No.: US 2025/0233320 A1**

(43) **Pub. Date: Jul. 17, 2025**

(54) **MULTI-BAND MULTI-FEED PATCH ANTENNA AND USER EQUIPMENT COMPRISING THE SAME**

*H01Q 9/04* (2006.01)

*H01Q 21/08* (2006.01)

(52) **U.S. Cl.**

CPC ..... *H01Q 21/065* (2013.01); *H01Q 1/38* (2013.01); *H01Q 9/0407* (2013.01); *H01Q 21/08* (2013.01)

(71) Applicant: **Huawei Technologies Co., Ltd.**,  
Shenzhen (CN)

(72) Inventors: **Ruiyuan Tian**, Helsinki (FI); **Weibo Peng**, Shenzhen (CN); **Lin Yuan**,  
Shanghai (CN)

(57) **ABSTRACT**

(21) Appl. No.: **18/690,617**

(22) PCT Filed: **Sep. 10, 2021**

(86) PCT No.: **PCT/CN2021/117776**

§ 371 (c)(1),

(2) Date: **Mar. 8, 2024**

**Publication Classification**

(51) **Int. Cl.**

*H01Q 21/06* (2006.01)

*H01Q 1/38* (2006.01)

Embodiments relate to patch antennas and devices utilizing patch antennas. Some embodiments comprise at least two different arrays of conductive patches arranged on one side of a dielectric substrate. Each of the at least two arrays of conductive patches supports a different frequency band. Moreover, each of the at least two arrays of conductive patches is provided with separated feeding. Additionally, each conductive patch of one or more of the at least two arrays of conductive patches is implemented as a combination two conductive sub-patches separated by a gap. In some embodiments, the patch antenna is suitable for integration into a display structure of a UE or other device.

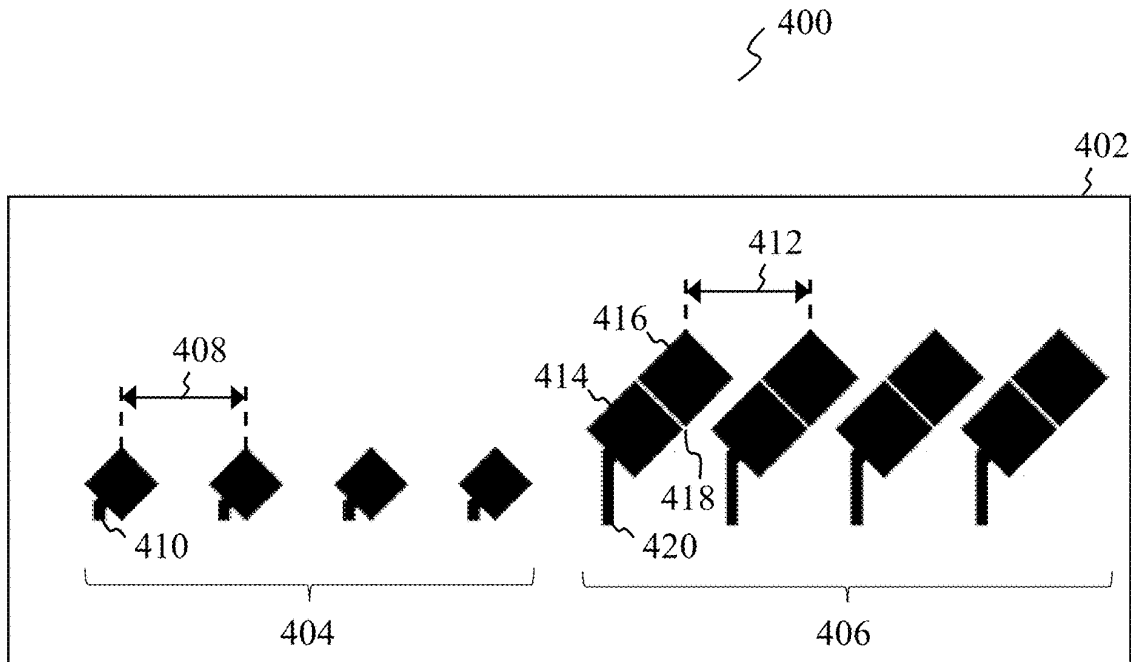



(19) **United States**

(12) **Patent Application Publication**  
**Xu et al.**

(10) **Pub. No.: US 2025/0233620 A1**

(43) **Pub. Date: Jul. 17, 2025**

(54) **METHODS AND APPARATUS FOR JOINT PRECODING IN COORDINATED OPERATION OF USER EQUIPMENT (UE)**

(71) Applicant: **Huawei Technologies Co., Ltd.**,  
Shenzhen (CN)

(72) Inventors: **Hua Xu**, Ottawa (CA); **Jianglei Ma**,  
Ottawa (CA)

(21) Appl. No.: **19/095,994**

(22) Filed: **Mar. 31, 2025**

**Publication Classification**

(51) **Int. Cl.**  
*H04B 7/024* (2017.01)  
*H04B 7/0456* (2017.01)  
*H04L 5/00* (2006.01)  
(52) **U.S. Cl.**  
CPC ..... *H04B 7/024* (2013.01); *H04B 7/0456*  
(2013.01); *H04L 5/0026* (2013.01)

(57) **ABSTRACT**

Operation of user equipment (UE) is to be coordinated with one or more other UEs for joint precoding and transmission of data to a communication device in a wireless communication network. Relationship information indicating a relationship between different reference signals that are communicated between a UE and the communication device or a relationship between a reference signal and a corresponding antenna beam for the transmission of data after the precoding is communicated in the wireless communication network. The UEs transmit the data after the joint precoding has been applied to the data, and the communication device receives transmissions of the data from the UEs.

**Related U.S. Application Data**  
(63) Continuation of application No. PCT/CN2023/123092, filed on Oct. 4, 2023.  
(60) Provisional application No. 63/415,367, filed on Oct. 12, 2022.

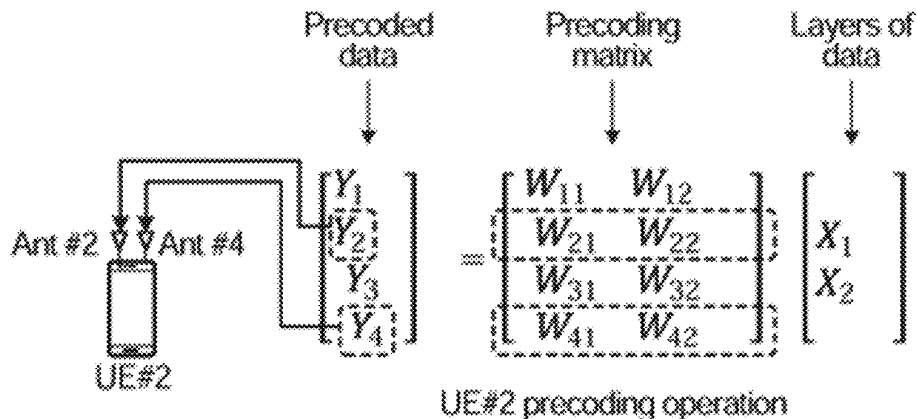
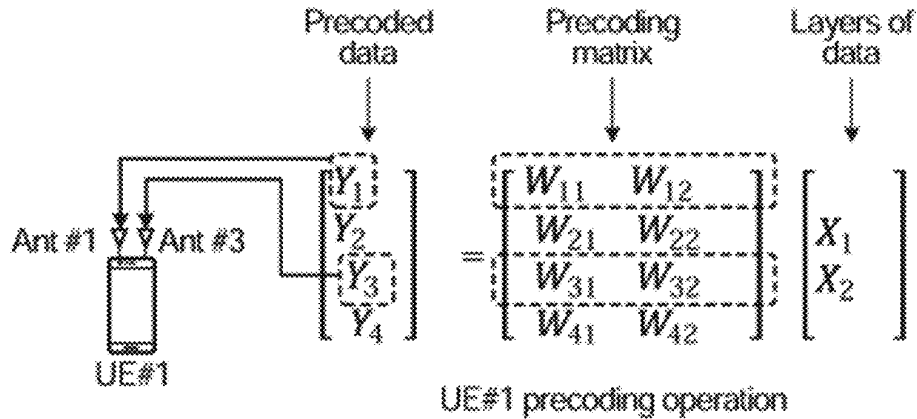



US 20250233630A1

(19) **United States**

(12) **Patent Application Publication**  
**Zhang et al.**

(10) **Pub. No.: US 2025/0233630 A1**

(43) **Pub. Date: Jul. 17, 2025**

(54) **METHODS AND APPARATUS FOR CSI REPORTING ON MULTI-PANEL PUSCH**

**Publication Classification**

(71) Applicant: **APPLE INC.**, Cupertino, CA (US)

(51) **Int. Cl.**  
*H04B 7/06* (2006.01)  
*H04W 24/10* (2009.01)  
*H04W 72/1268* (2023.01)

(72) Inventors: **Yushu Zhang**, Beijing (CN); **Dawei Zhang**, Saratoga, CA (US); **Weidong Yang**, San Diego, CA (US); **Chunxuan Ye**, San Diego, CA (US); **Seyed Ali Akbar Fakoorian**, San Diego, CA (US); **Huaning Niu**, San Jose, CA (US); **Hong He**, San Jose, CA (US); **Haitong Sun**, Cupertino, CA (US); **Wei Zeng**, Saratoga, CA (US)

(52) **U.S. Cl.**  
CPC ..... *H04B 7/0626* (2013.01); *H04W 24/10* (2013.01); *H04W 72/1268* (2013.01)

(57) **ABSTRACT**

A user equipment (UE) is configured for multi-panel physical uplink shared channel (PUSCH) transmission using multiple antenna panels. The UE may send a UE capability message to a base station to indicate a plurality of channel state information (CSI) report schemes supported by the UE. The UE processes a signal from the base station to configure the UE for a selected CSI report scheme of the plurality of CSI report schemes. The UE determines whether one or more condition associated with the selected CSI report scheme is satisfied. The UE transmits, to the base station, CSI in one or more PUSCH from one or more of the multiple antenna panels based on whether the one or more condition associated with the selected CSI report scheme is satisfied.

(21) Appl. No.: **18/853,611**

(22) PCT Filed: **Mar. 23, 2023**

(86) PCT No.: **PCT/US2023/064859**

§ 371 (c)(1),

(2) Date: **Oct. 2, 2024**

**Related U.S. Application Data**

(60) Provisional application No. 63/363,079, filed on Apr. 15, 2022.

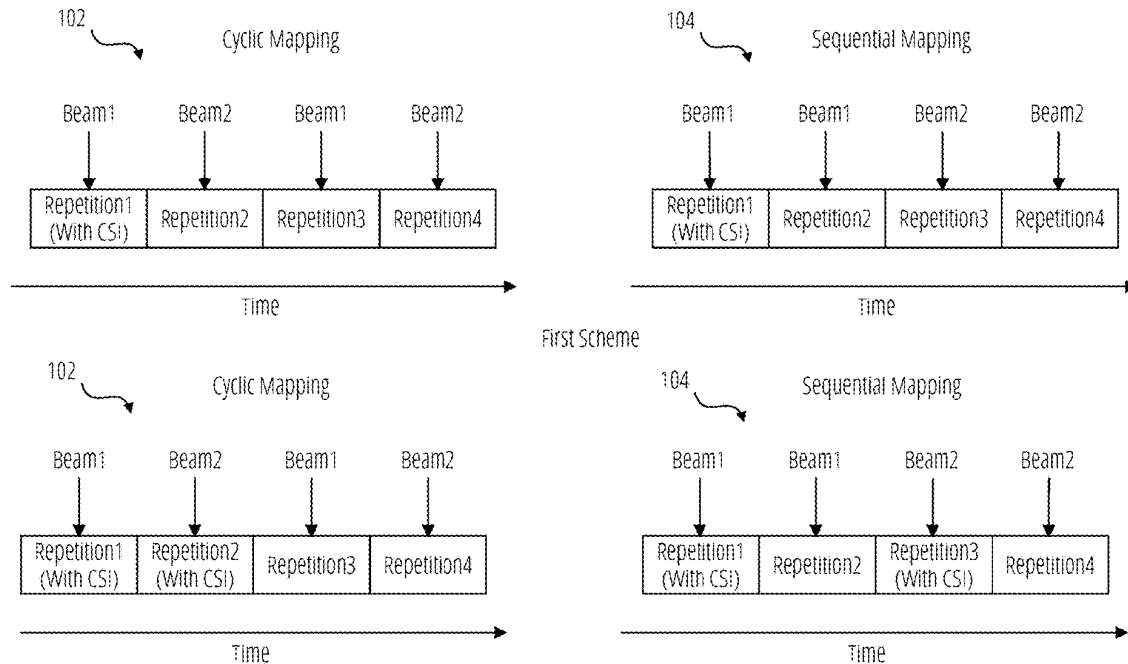





US 20250233638A1

(19) **United States**

(12) **Patent Application Publication** (10) **Pub. No.: US 2025/0233638 A1**  
**CHOU et al.** (43) **Pub. Date: Jul. 17, 2025**

(54) **BEAM SEARCH PROCEDURES FOR MULTIPLE SPATIAL STREAMS**

(52) **U.S. Cl.**  
CPC ..... **H04B 7/06952** (2023.05); **H04B 7/0617** (2013.01); **H04B 7/10** (2013.01)

(71) Applicant: **QUALCOMM Incorporated**, San Diego, CA (US)

(57) **ABSTRACT**

(72) Inventors: **Tzu-Hsuan CHOU**, San Diego, CA (US); **Lin YANG**, San Diego, CA (US); **Alecsander Petru EITAN**, Haifa (IL); **Bin TIAN**, San Diego, CA (US)

This disclosure provides methods, components, devices, and systems for beam search procedures for multiple spatial streams. Some aspects more specifically relate to beamforming training procedures for multiple spatial streams. The beamforming training procedures may provide beam separation between beams during the training procedure to prevent selecting beams which lead to inter-stream interference. In some examples, a multi-stream beamforming training procedure described herein may use antenna polarization to provide beam separation. For example, different radio frequency (RF) chains may use different antenna polarizations. Additionally, or alternatively, a multi-stream beamforming training procedure may provide beam separation through antenna orientation, where different RF chains use mutually exclusive beam search regions. Additionally, or alternatively, the responder wireless communication device may iteratively select beamforming directions for spatial streams, or one-by-one, and the initiator wireless communication device may perform additional beam searches excluding directions within beam widths of previously-selected beams.

(21) Appl. No.: **18/768,429**

(22) Filed: **Jul. 10, 2024**

**Related U.S. Application Data**

(60) Provisional application No. 63/619,940, filed on Jan. 11, 2024.

**Publication Classification**

(51) **Int. Cl.**  
**H04B 7/06** (2006.01)  
**H04B 7/10** (2017.01)

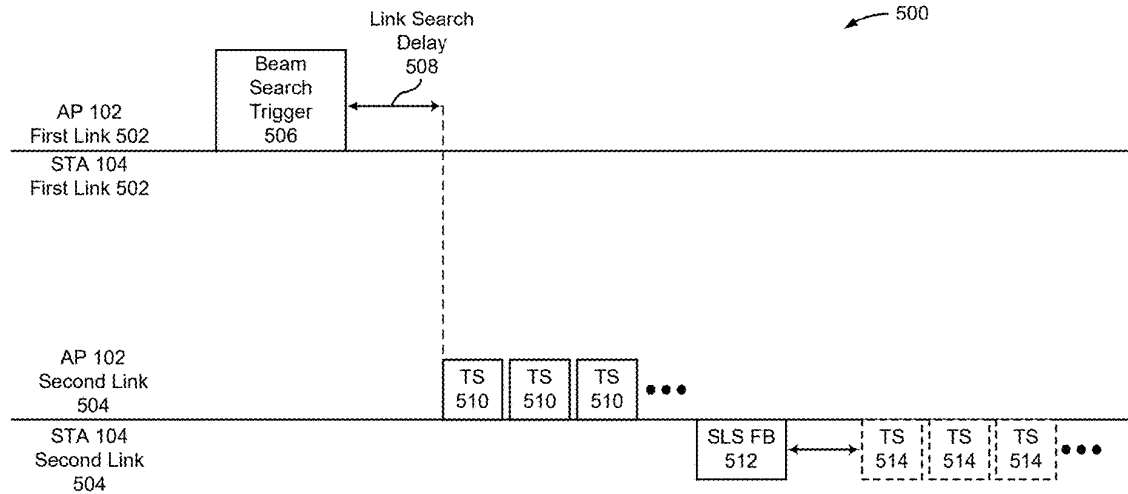



US 20250233776A1

(19) **United States**

(12) **Patent Application Publication** (10) **Pub. No.: US 2025/0233776 A1**

**Jeon et al.**

(43) **Pub. Date: Jul. 17, 2025**

(54) **MOBILE DEVICE COMMUNICATION**

(52) **U.S. Cl.**

(71) Applicant: **SAMSUNG ELECTRONICS CO., LTD.**, Suwon-si (KR)

CPC ..... **H04L 25/0224** (2013.01); **H04B 7/0695** (2013.01); **H04W 28/18** (2013.01); **H04W 48/16** (2013.01)

(72) Inventors: **Eun Sung Jeon**, Suwon-si (KR);  
**Myeongjin Kim**, Suwon-si (KR);  
**Chulho Chung**, Suwon-si (KR)

(57) **ABSTRACT**

A mobile device includes an antenna that communicates a wireless signal with an access point, a transceiver that communicates a signal with the antenna, and a processor that receives a first announcement packet and a sounding packet received through the antenna and the transceiver, estimates a channel based on the sounding packet, and transmits full information about a result of the channel estimation through the transceiver and the antenna. The processor receives a second announcement packet and the sounding packet received through the antenna and the transceiver, estimates a channel based on the sounding packet, and transmits partial information selected from full information about a result of the channel estimation through the transceiver and the antenna. The second announcement packet includes selection information indicating the selected partial information, and the selection information is determined based on a machine learning module included in the access point.

(21) Appl. No.: **18/990,919**

(22) Filed: **Dec. 20, 2024**

(30) **Foreign Application Priority Data**

Jan. 15, 2024 (KR) ..... 10-2024-0006140

**Publication Classification**

(51) **Int. Cl.**

**H04L 25/02** (2006.01)

**H04B 7/06** (2006.01)

**H04W 28/18** (2009.01)

**H04W 48/16** (2009.01)

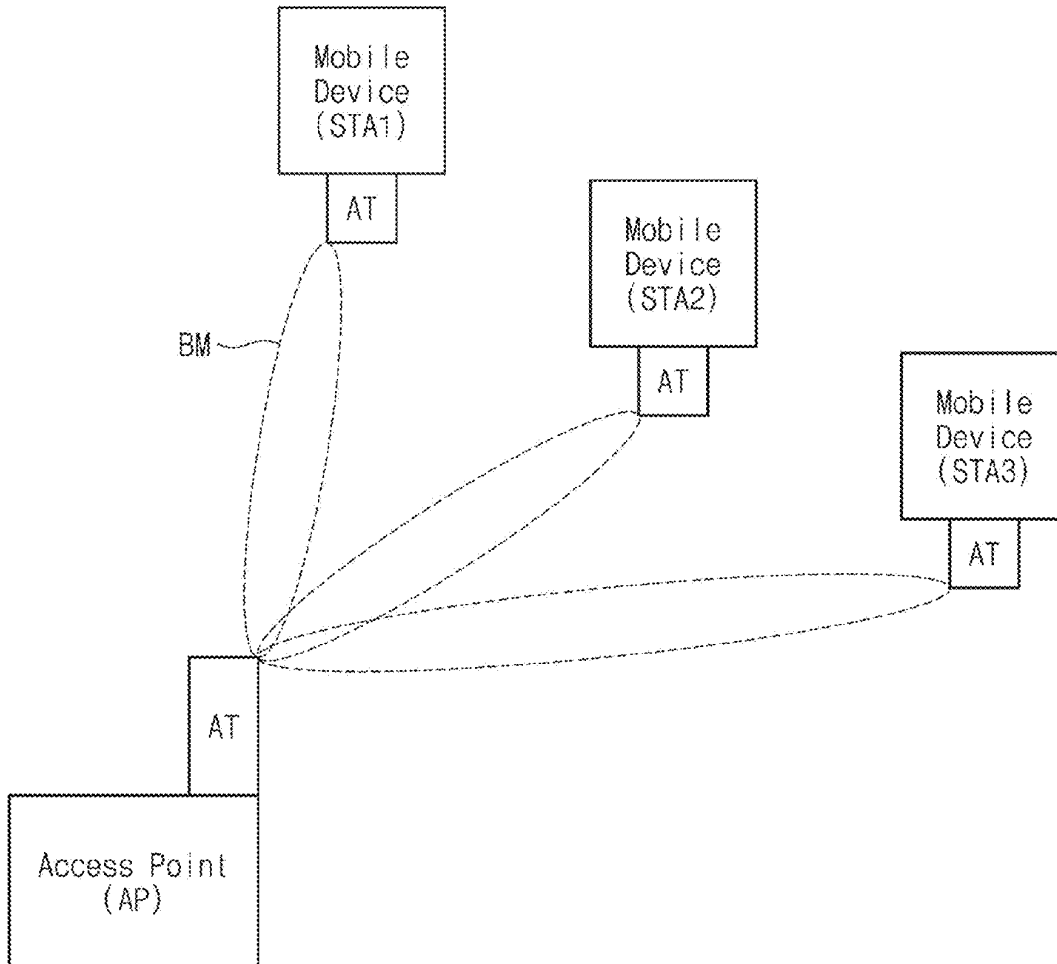



US 20250234330A1

(19) **United States**

(12) **Patent Application Publication**  
**Grandhe et al.**

(10) **Pub. No.: US 2025/0234330 A1**

(43) **Pub. Date: Jul. 17, 2025**

(54) **WIFI RANGING**

**Publication Classification**

(71) Applicant: **NXP USA, Inc.**, AUSTIN, TX (US)

(51) **Int. Cl.**  
**H04W 64/00** (2009.01)

**H04W 24/08** (2009.01)

(72) Inventors: **Niranjan Grandhe**, Fremont, CA (US);  
**Christian Raimund Berger**, San Jose,  
CA (US)

(52) **U.S. Cl.**  
CPC ..... **H04W 64/006** (2013.01); **H04W 24/08**  
(2013.01)

(21) Appl. No.: **18/965,616**

(57) **ABSTRACT**

(22) Filed: **Dec. 2, 2024**

One example discloses a first wireless communication device, including: a transceiver configured to be coupled to an antenna; a controller coupled to the transceiver; wherein the controller is configured to calculate a range to a second wireless communication device based on a set of exchanged messages; wherein the controller is configured to calculate the range while limiting at least one of: a set of allowed message repetitions and a set of allowed LTF (long training frame) totals, for channel bandwidths (BW) greater than 160 MHz.

**Related U.S. Application Data**

(60) Provisional application No. 63/621,911, filed on Jan. 17, 2024.

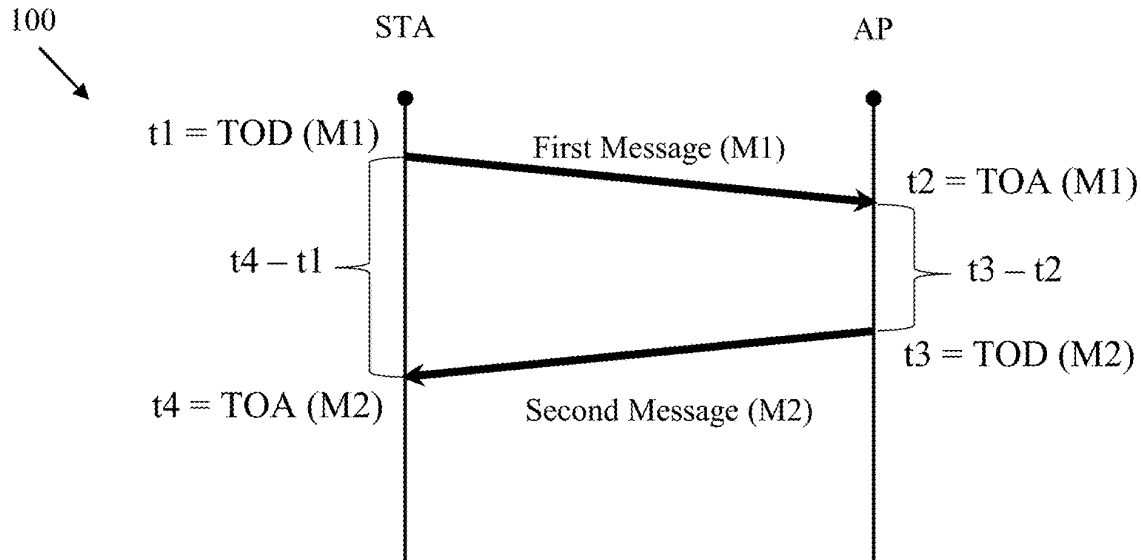



US 20250239756A1

(19) **United States**

(12) **Patent Application Publication**  
**Fang et al.**

(10) **Pub. No.: US 2025/0239756 A1**

(43) **Pub. Date: Jul. 24, 2025**

(54) **COMPACT PRINTED CIRCUIT BOARD  
IMPLEMENTED ANTENNA**

(52) **U.S. Cl.**  
CPC ..... **H01Q 1/2291** (2013.01)

(71) Applicant: **Honeywell International Inc.,**  
Charlotte, NC (US)

(57) **ABSTRACT**

(72) Inventors: **Bo Fang,** Tianjin (CN); **Xueqin Shen,**  
Tianjin (CN); **Yi Bin Wu,** Tianjin (CN)

(21) Appl. No.: **19/013,957**

(22) Filed: **Jan. 8, 2025**

(30) **Foreign Application Priority Data**

Jan. 19, 2024 (WO) ..... PCT/CN2024/073188

**Publication Classification**

(51) **Int. Cl.**  
**H01Q 1/22** (2006.01)

A printed circuit board-implemented antenna may be used in a smart socket. The printed circuit board implemented-antenna includes a plurality of antenna legs arranged within a rectangular area on a printed circuit board of less than 80 square millimeters with each of the plurality of antenna legs formed using one or more metal layers of the printed circuit board, the plurality of antenna legs arranged to provide a return loss of less than -10 dB at 2.4 GHz. The printed circuit board-implemented antenna may be disposed within the smart socket in such a way as to ensure that there are no packaged electrical components in front of or behind the printed circuit board-implemented antenna.

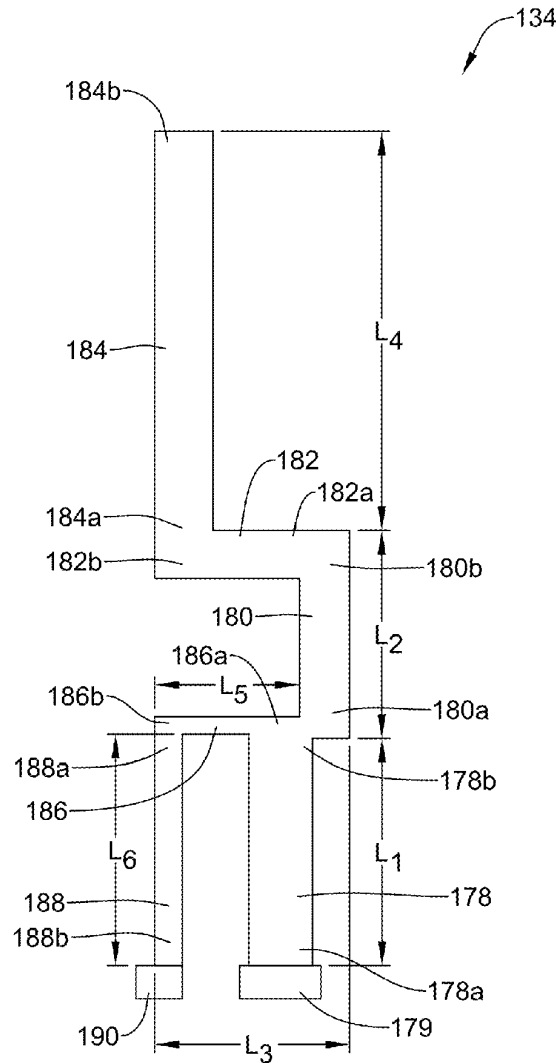



US 20250239760A1

(19) **United States**

(12) **Patent Application Publication**  
**IZAWA et al.**

(10) **Pub. No.: US 2025/0239760 A1**

(43) **Pub. Date: Jul. 24, 2025**

(54) **ANTENNA SUBSTRATE AND ANTENNA MODULE**

**Publication Classification**

(71) Applicant: **Murata Manufacturing Co., Ltd.**,  
Nagaokakyo-shi (JP)

(51) **Int. Cl.**  
*H01Q 1/52* (2006.01)  
*H01Q 1/48* (2006.01)  
*H01Q 9/04* (2006.01)  
*H01Q 9/30* (2006.01)

(72) Inventors: **Masahiro IZAWA**, Nagaokakyo-shi (JP); **Kaneo NOMIYAMA**,  
Nagaokakyo-shi (JP)

(52) **U.S. Cl.**  
CPC ..... *H01Q 1/521* (2013.01); *H01Q 1/48* (2013.01); *H01Q 9/0407* (2013.01); *H01Q 9/30* (2013.01)

(73) Assignee: **Murata Manufacturing Co., Ltd.**,  
Nagaokakyo-shi (JP)

(57) **ABSTRACT**

(21) Appl. No.: **19/175,230**

An antenna substrate includes a baseplate, a first radiation electrode, a second radiation electrode disposed on the baseplate spatially apart from the first radiation electrode in a second direction (X), and a ground portion that is disposed on the baseplate and that is common to the first and the second radiation electrode. The ground portion includes a ground electrode that faces the first radiation electrode when seen from the first direction (Z), a connection line between the first radiation electrode and the second radiation electrode when seen from the first direction and that has a size that is smaller than a size of the ground electrode in a third direction (Y) orthogonal to the second direction when seen from the first direction (Z), and a stub.

(22) Filed: **Apr. 10, 2025**

**Related U.S. Application Data**

(63) Continuation of application No. PCT/JP2023/038868, filed on Oct. 27, 2023.

(30) **Foreign Application Priority Data**

Dec. 26, 2022 (JP) ..... 2022-208321

1

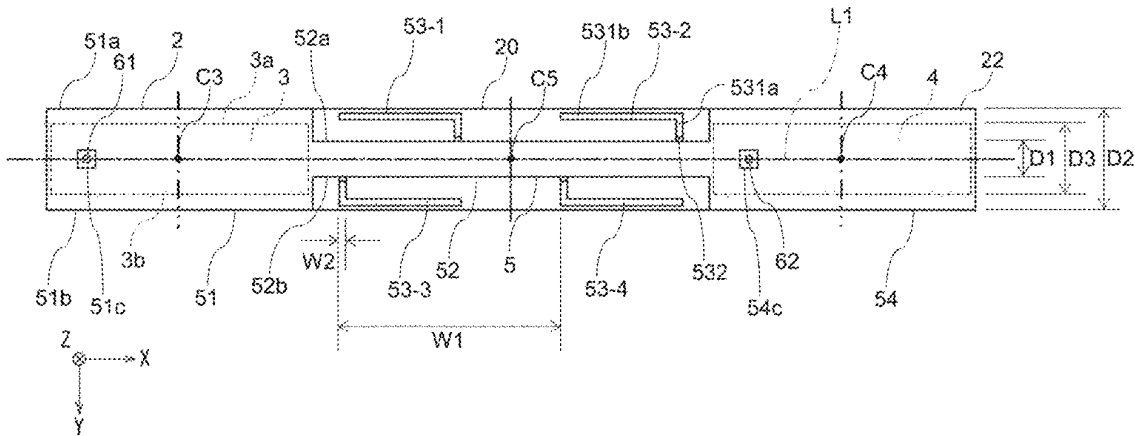



US 20250239771A1

(19) **United States**

(12) **Patent Application Publication**  
**ZHU et al.**

(10) **Pub. No.: US 2025/0239771 A1**

(43) **Pub. Date: Jul. 24, 2025**

(54) **ANTENNA STRUCTURE AND ELECTRONIC DEVICE**

*H01Q 1/48* (2006.01)

*H01Q 5/10* (2015.01)

*H01Q 5/50* (2015.01)

(71) Applicant: **Wistron NeWeb Corporation**, Hsinchu (TW)

(52) **U.S. Cl.**

CPC ..... *H01Q 9/0407* (2013.01); *H01Q 1/2266*

(2013.01); *H01Q 1/48* (2013.01); *H01Q 5/10*

(2015.01); *H01Q 5/50* (2015.01)

(72) Inventors: **Jia-Le ZHU**, Hsinchu (TW); **Chia-Hao CHANG**, Hsinchu (TW); **Ching-Wen CHEN**, Hsinchu (TW); **Cheng-Wei CHIANG**, Hsinchu (TW)

(57)

**ABSTRACT**

An antenna structure and an electronic device are proposed. The antenna structure includes a feeding source, a main radiation portion, a grounding portion and a floating portion. The main radiation portion is connected to the feeding source and extends toward a first direction. The grounding portion is connected to a grounding layer, and a first gap is formed between the grounding portion and the main radiation portion. The grounding portion extends toward the first direction. A second gap is formed between the floating portion and the grounding portion. The floating portion extends toward the first direction. The main radiation portion, the grounding portion and the floating portion are arranged sequentially along a second direction.

(21) Appl. No.: **19/011,712**

(22) Filed: **Jan. 7, 2025**

(30) **Foreign Application Priority Data**

Jan. 24, 2024 (TW) ..... 113102791

**Publication Classification**

(51) **Int. Cl.**

*H01Q 9/04* (2006.01)

*H01Q 1/22* (2006.01)

200a

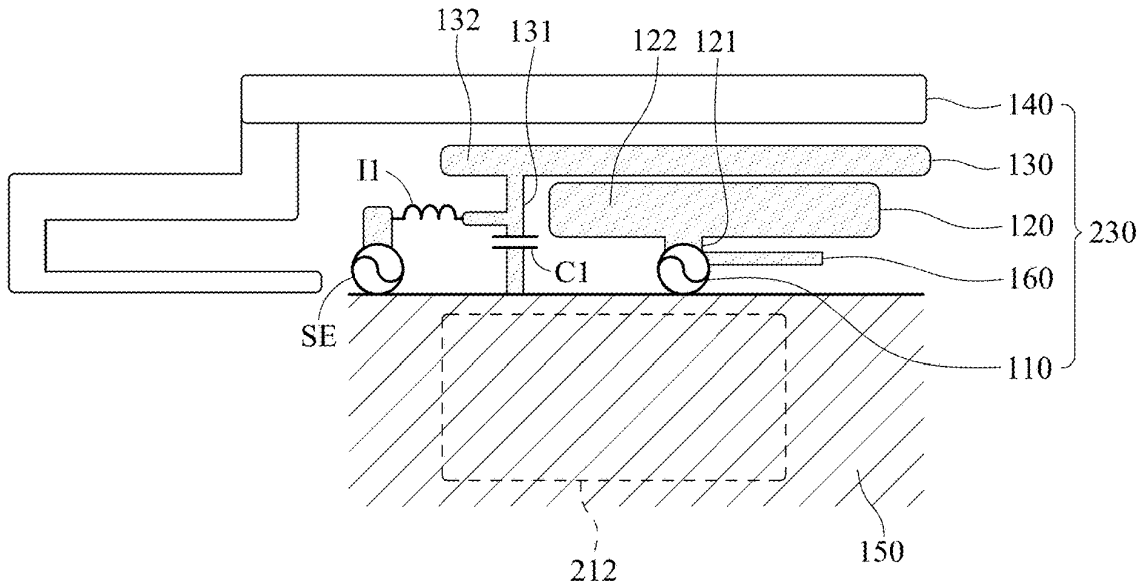
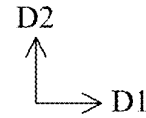



(19) **United States**

(12) **Patent Application Publication**  
**KIM et al.**

(10) **Pub. No.: US 2025/0239774 A1**

(43) **Pub. Date: Jul. 24, 2025**

(54) **ANTENNA AND ELECTRONIC DEVICE  
COMPRISING SAME**

*H01Q 21/30* (2006.01)

*H04B 1/401* (2015.01)

(71) Applicant: **SAMSUNG ELECTRONICS CO.,  
LTD.**, Suwon-si (KR)

(52) **U.S. Cl.**

CPC ..... *H01Q 9/045* (2013.01); *H01Q 5/371*  
(2015.01); *H01Q 21/30* (2013.01); *H04B*  
*1/401* (2013.01)

(72) Inventors: **Jongsuk KIM**, Suwon-si (KR); **Jiyeon  
YUN**, Suwon-si (KR); **Gyusub KIM**,  
Suwon-si (KR); **Seunghwan KIM**,  
Suwon-si (KR)

(57)

**ABSTRACT**

(21) Appl. No.: **19/176,591**

(22) Filed: **Apr. 11, 2025**

**Related U.S. Application Data**

(63) Continuation of application No. PCT/KR2023/  
015599, filed on Oct. 11, 2023.

(30) **Foreign Application Priority Data**

Oct. 11, 2022 (KR) ..... 10-2022-0129942  
Nov. 24, 2022 (KR) ..... 10-2022-0159741

**Publication Classification**

(51) **Int. Cl.**

*H01Q 9/04* (2006.01)

*H01Q 5/371* (2015.01)

An electronic device may include: at least one housing including a first side surface and a second side surface extending from the first side surface in the vertical direction; a conductor, which is arranged in the housing and extends along the second side surface from the first side surface; a substrate including a ground plane arranged in the inner space of the housing; and a wireless communication circuit which is arranged in the substrate, and which is configured to transmit or receive a wireless signal in a first frequency band through a first point of the conductor, wherein: the first point is positioned at the corner or adjacent to the corner of the conductor; and, in the conductor, a first length of a first radiating portion positioned at one side from the first point can be the same, on the basis of the first frequency band, as a second length of a second radiating portion positioned at the other side.

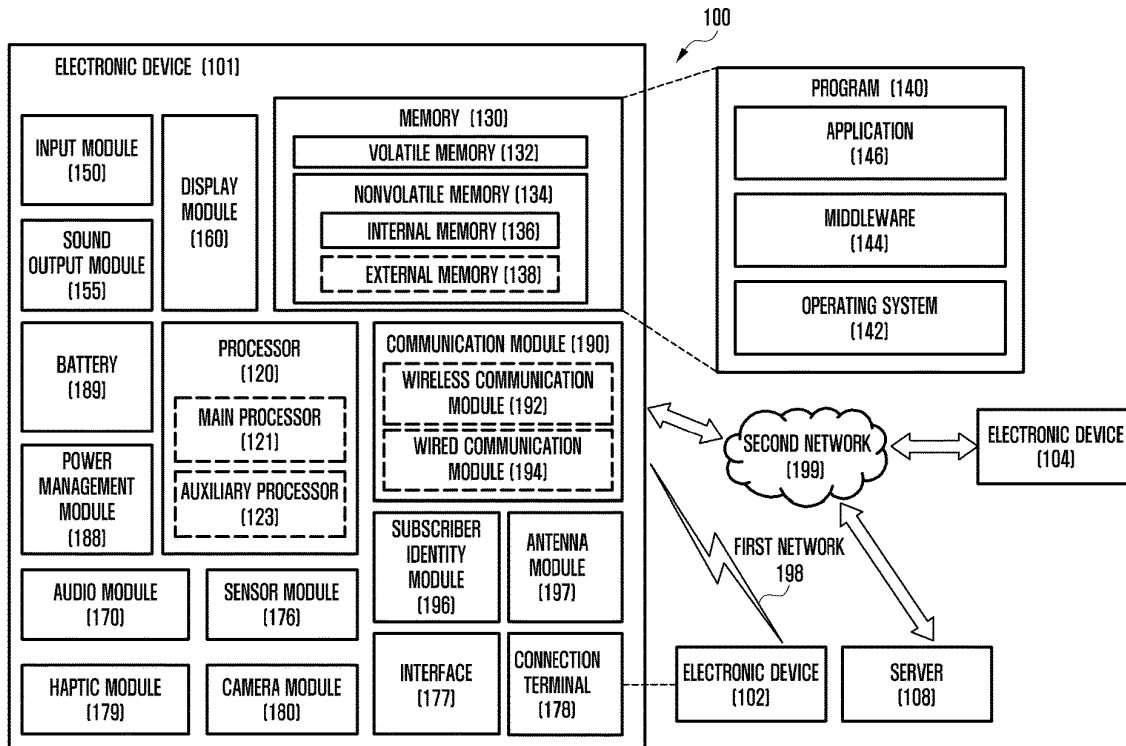



US 20250239775A1

(19) **United States**

(12) **Patent Application Publication**  
**YANG**

(10) **Pub. No.: US 2025/0239775 A1**

(43) **Pub. Date: Jul. 24, 2025**

(54) **ANTENNA STRUCTURE AND ANTENNA SYSTEM**

(52) **U.S. Cl.**  
CPC ..... **H01Q 9/16** (2013.01); **H01Q 9/0421** (2013.01)

(71) Applicant: **TP-LINK CORPORATION LIMITED**, Hong Kong (CN)

(72) Inventor: **Junyu YANG**, Chengdu, Sichuan (CN)

(57) **ABSTRACT**

(21) Appl. No.: **18/703,317**

(22) PCT Filed: **Dec. 23, 2022**

(86) PCT No.: **PCT/CN2022/141678**

§ 371 (c)(1),

(2) Date: **Apr. 19, 2024**

Provided are an antenna structure and an antenna system. The antenna structure includes a dielectric substrate, a two-wire parallel line, a first dipole antenna, a second dipole antenna and a reconfiguration structure; where the dielectric substrate includes a front surface and a back surface that are opposite each other; the two-wire parallel line includes a front conductor and a back conductor that are parallel to each other; the first dipole antenna includes a first radiation arm and a second radiation arm, and the second dipole antenna includes a third radiation arm and a fourth radiation arm; the reconfiguration structure includes a front unit, a back unit and a switching device; two ends of the switching device are connected to the front unit and the back unit respectively; and the two-wire parallel line is configured to transmit a radio frequency signal and a control signal.

(30) **Foreign Application Priority Data**

Jan. 13, 2022 (CN) ..... 202210039312.8

Jan. 30, 2022 (CN) ..... 202210114584.X

**Publication Classification**

(51) **Int. Cl.**  
**H01Q 9/16** (2006.01)  
**H01Q 9/04** (2006.01)

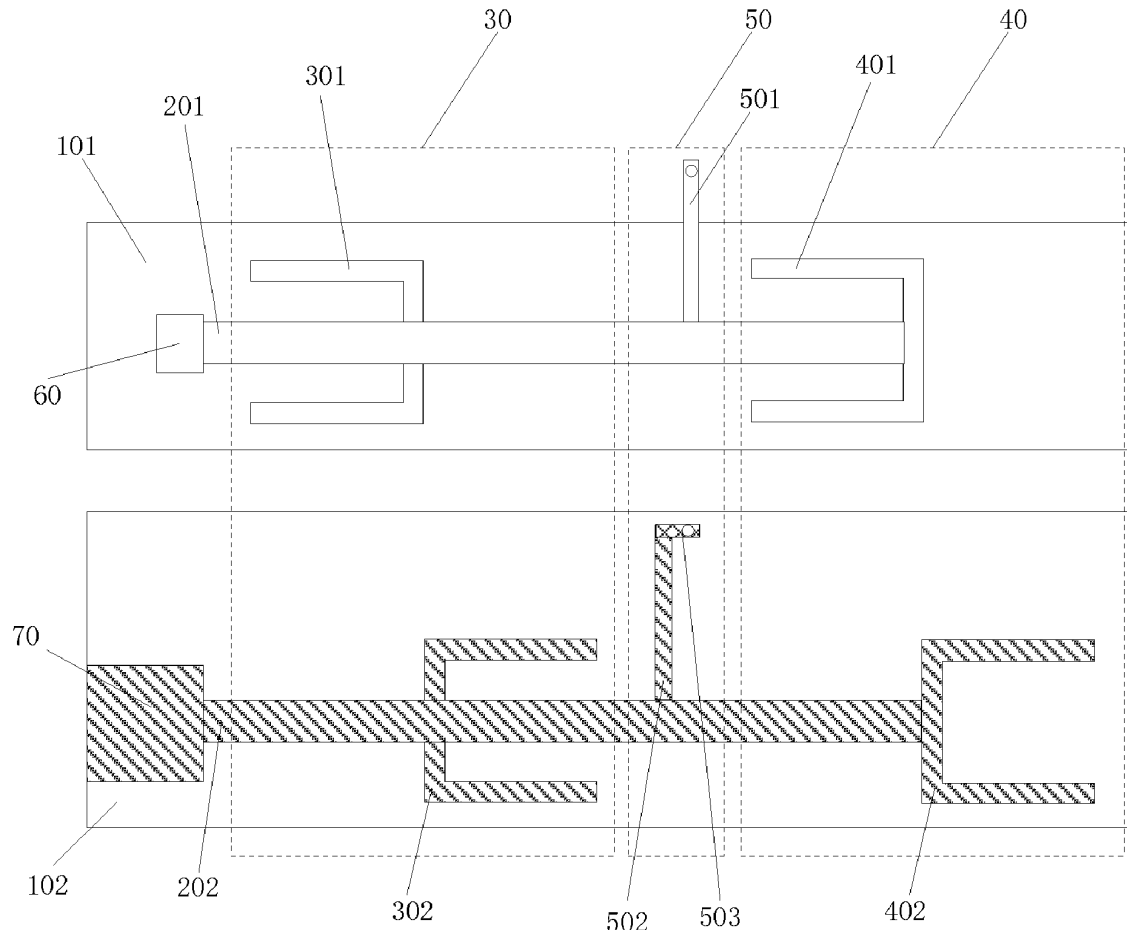



US 20250239779A1

(19) **United States**

(12) **Patent Application Publication**  
**Chen et al.**

(10) **Pub. No.: US 2025/0239779 A1**

(43) **Pub. Date: Jul. 24, 2025**

(54) **HORIZONTALLY POLARIZED  
OMNIDIRECTIONAL MULTI-BAND  
ANTENNA STRUCTURE**

(52) **U.S. Cl.**  
CPC ..... **H01Q 13/08** (2013.01); **H01Q 5/50**  
(2015.01)

(71) Applicant: **Alpha Networks Inc.**, Hsinchu City  
(TW)

(57) **ABSTRACT**

(72) Inventors: **Guan-Ting Chen**, Hsinchu City (TW);  
**Kuang-Wei Lin**, Hsinchu City (TW)

A horizontally polarized omnidirectional multi-band antenna structure includes a substrate and two structurally-symmetric radiators, each being provided on a layout area on one of the two opposite sides of the substrate, and including a X-shaped primary microstrip line, four secondary microstrip lines, four primary stubs, four secondary stubs and four resonators. The primary microstrip line has four end points arranged with the secondary microstrip lines along different extending directions. The primary stubs extend along different directions from four sections of the primary microstrip line. Each secondary microstrip line is provided with one of the secondary stubs. Resonators are provided between four end points of the primary microstrip line and the primary stubs. The antenna structure supports WiFi 6E/WiFi 7 frequency bands including the 2 GHz, 5 GHz and 6 GHz bands, has characteristics of horizontal polarization and omnidirectionality, and effectively satisfies the needs for miniaturized multi-band and wide band antennas.

(73) Assignee: **Alpha Networks Inc.**, Hsinchu City  
(TW)

(21) Appl. No.: **18/666,775**

(22) Filed: **May 16, 2024**

(30) **Foreign Application Priority Data**

Jan. 24, 2024 (TW) ..... 113102799

**Publication Classification**

(51) **Int. Cl.**  
**H01Q 13/08** (2006.01)  
**H01Q 5/50** (2015.01)

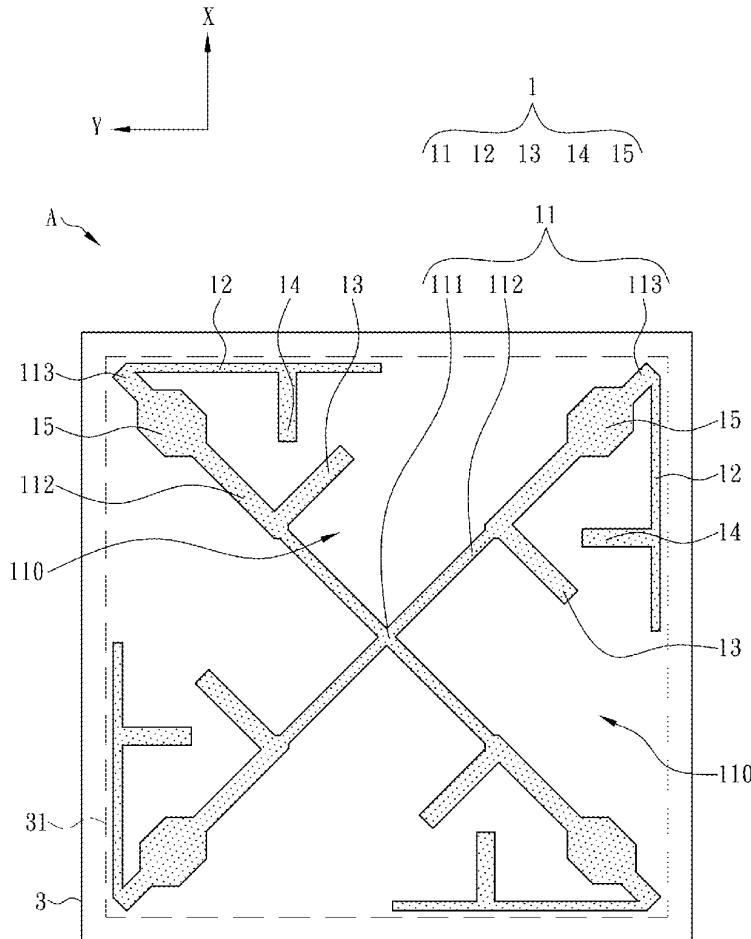



US 20250239780A1

(19) **United States**

(12) **Patent Application Publication**  
**NASU et al.**

(10) **Pub. No.: US 2025/0239780 A1**

(43) **Pub. Date: Jul. 24, 2025**

(54) **ANTENNA DEVICE AND ELECTRONIC APPARATUS**

**Publication Classification**

(71) Applicant: **Murata Manufacturing Co., Ltd.**,  
Nagaokakyo-shi (JP)

(51) **Int. Cl.**  
**H01Q 13/10** (2006.01)  
**H01Q 7/00** (2006.01)

(72) Inventors: **Takafumi NASU**, Nagaokakyo-shi (JP);  
**Shigeyuki FUJIEDA**, Nagaokakyo-shi (JP)

(52) **U.S. Cl.**  
CPC ..... **H01Q 13/106** (2013.01); **H01Q 7/00** (2013.01)

(21) Appl. No.: **19/175,238**

(57) **ABSTRACT**

(22) Filed: **Apr. 10, 2025**

**Related U.S. Application Data**

(63) Continuation of application No. PCT/JP2023/043793, filed on Dec. 7, 2023.

**Foreign Application Priority Data**

Dec. 9, 2022 (JP) ..... 2022-196958  
May 30, 2023 (JP) ..... 2023-088797

An antenna device includes a conductor with a planar shape and a slot, first and second excitation electrodes at positions corresponding to the slot, and first and second coils. A first end of the first coil is electrically connected to the first excitation electrode, and a second end of the first coil is connected to a feed circuit. One end of the second coil is electrically connected to the second excitation electrode. The first and second coils are positioned to be magnetically coupled with each other.

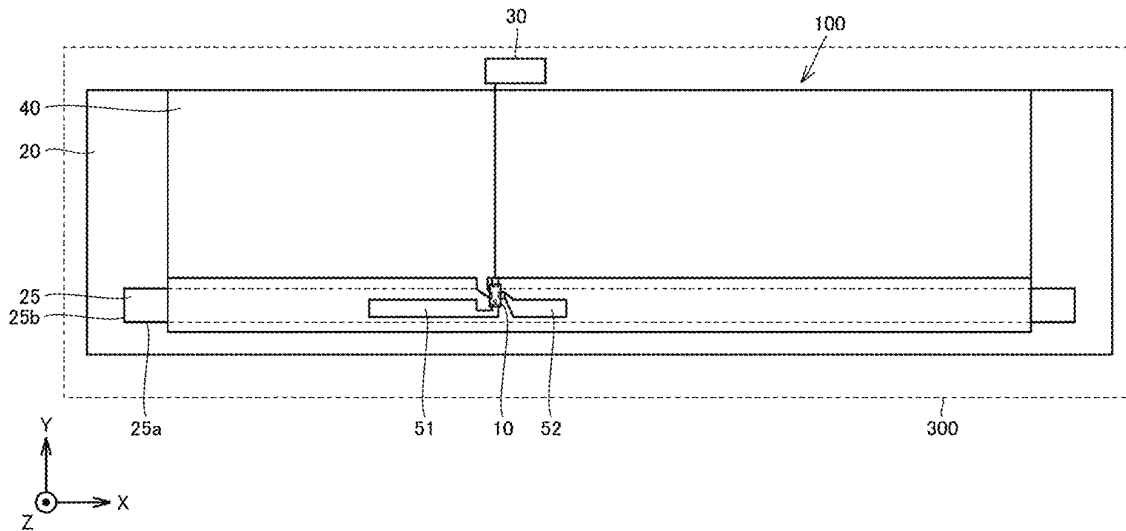



US 20250239782A1

(19) **United States**

(12) **Patent Application Publication**  
**TAN et al.**

(10) **Pub. No.: US 2025/0239782 A1**

(43) **Pub. Date: Jul. 24, 2025**

(54) **PHASED ARRAY ANTENNA MODULE WITH LOADED METAMATERIALS, RF CIRCUITRY, AND 5G MOBILE DEVICE**

**Publication Classification**

(71) Applicant: **HUIZHOU SPEED WIRELESS TECHNOLOGY CO., LTD.,**  
HUIZHOU (CN)

(51) **Int. Cl.**  
**H01Q 15/00** (2006.01)  
**H01Q 3/26** (2006.01)

(72) Inventors: **GUANNAN TAN, HUIZHOU (CN);**  
**QINFANG LI, HUIZHOU (CN)**

(52) **U.S. Cl.**  
CPC ..... **H01Q 15/0086** (2013.01); **H01Q 3/2676**  
(2013.01)

(73) Assignee: **HUIZHOU SPEED WIRELESS TECHNOLOGY CO., LTD.,**  
HUIZHOU (CN)

(57) **ABSTRACT**

(21) Appl. No.: **19/033,513**

The present disclosure provides a phased array antenna module loaded with metamaterials, an RF circuit, and a 5G mobile device. The module includes a millimeter-wave RF module with at least one emission surface and an arc-shaped metamaterial structure featuring multiple stacked layers, each with periodically distributed metallic unit structures, each concave surface of the metamaterial structure aligns with the corresponding emission surface, and the metallic unit structures in the same layer are of equal size. Across layers, these structures are arranged in a one-to-one correspondence, with sizes sequentially increasing or decreasing along the stacking direction. This configuration improves gain, expands scanning angles, and minimizes scanning loss, offering enhanced performance and seamless integration with modern 5G devices.

(22) Filed: **Jan. 22, 2025**

**Related U.S. Application Data**

(63) Continuation of application No. PCT/CN2023/122715, filed on Sep. 28, 2023.

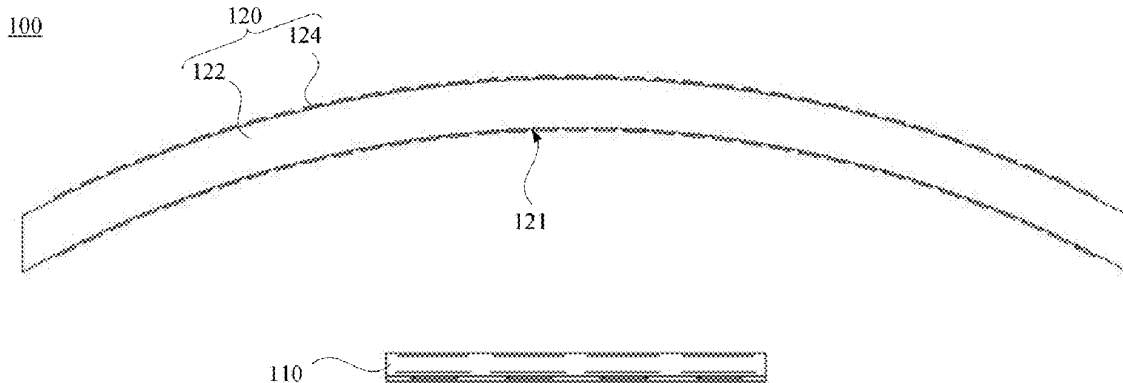



US 20250240047A1

(19) **United States**

(12) **Patent Application Publication**  
**SVENDSEN et al.**

(10) **Pub. No.: US 2025/0240047 A1**

(43) **Pub. Date: Jul. 24, 2025**

(54) **RADIO COMMUNICATION AT A FIRST  
FREQUENCY AND AT A SECOND  
DIFFERENT FREQUENCY**

(52) **U.S. Cl.**  
CPC ..... *H04B 1/40* (2013.01); *H01Q 1/50*  
(2013.01)

(71) Applicant: **Nokia Technologies Oy**, Espoo (FI)

(57) **ABSTRACT**

(72) Inventors: **Simon SVENDSEN**, Aalborg (DK);  
**Samantha CAPORAL DEL BARRIO**,  
Aalborg (DK)

An antenna system having at least a first operational bandwidth over at least a first frequency range and a second operational bandwidth over at least a second frequency range, higher frequency than the first frequency range comprising: an antenna radiator element;

(21) Appl. No.: **18/977,557**

at least a first feed for the first frequency range coupled to the antenna radiator element; a second feed for the second frequency range coupled to the antenna radiator element wherein the second frequency range is higher frequency than the first frequency range; and at least one discrete reactive component coupled to the antenna radiator element, wherein the at least one discrete reactive component has a self resonant frequency and wherein the at least one discrete reactive component is configured to control the first operational bandwidth (BW1) of the antenna system.

(22) Filed: **Dec. 11, 2024**

(30) **Foreign Application Priority Data**

Jan. 19, 2024 (GB) ..... 2400740.3

**Publication Classification**

(51) **Int. Cl.**  
*H04B 1/40* (2015.01)  
*H01Q 1/50* (2006.01)

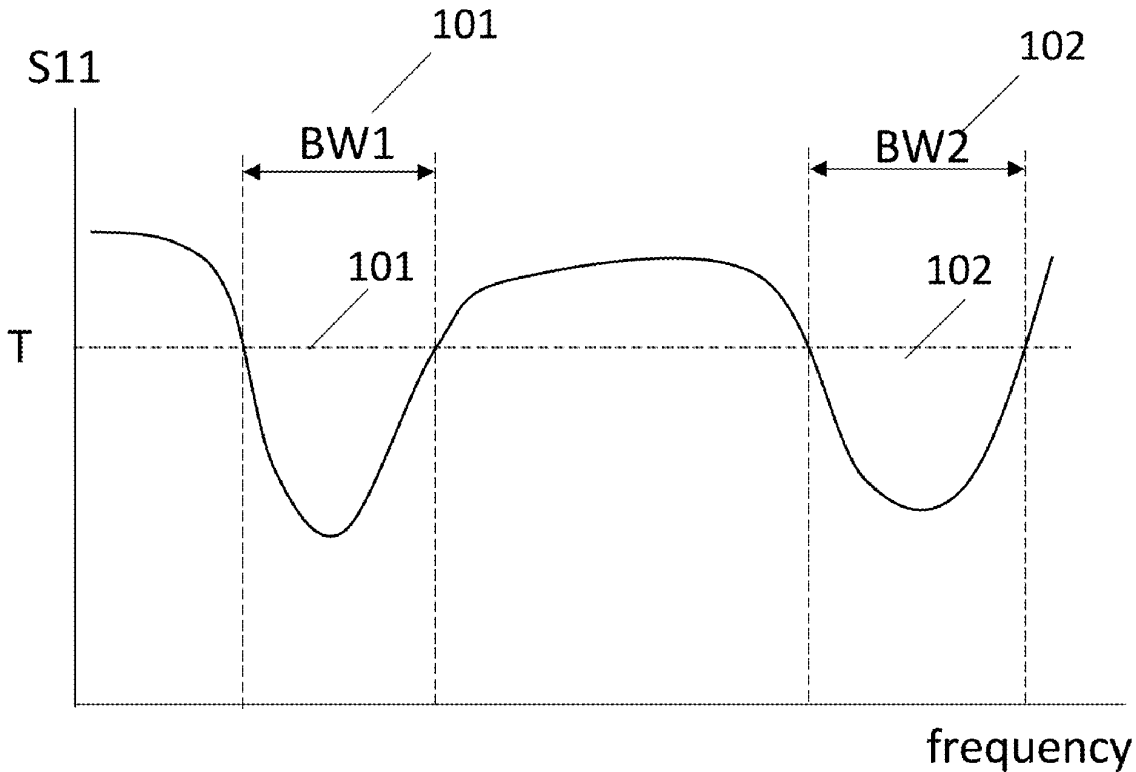



US 20250240049A1

(19) **United States**

(12) **Patent Application Publication**  
**NAM et al.**

(10) **Pub. No.: US 2025/0240049 A1**

(43) **Pub. Date: Jul. 24, 2025**

(54) **ANTENNA USING CONDUCTIVE PORTIONS AND ELECTRONIC DEVICE INCLUDING SAME**

**Publication Classification**

(51) **Int. Cl.**  
*H04B 1/40* (2015.01)  
*H04B 1/00* (2006.01)  
*H04B 1/3827* (2015.01)  
*H04B 17/19* (2015.01)

(52) **U.S. Cl.**  
 CPC ..... *H04B 1/40* (2013.01); *H04B 1/0064* (2013.01); *H04B 17/19* (2015.01); *H04B 1/3838* (2013.01)

(71) Applicant: **Samsung Electronics Co., Ltd.**,  
Suwon-si (KR)

(72) Inventors: **Hojung NAM**, Suwon-si (KR); **Shinho YOON**, Suwon-si (KR); **Himchan YUN**, Suwon-si (KR); **Museok BANG**, Suwon-si (KR); **Soonho HWANG**, Suwon-si (KR)

(21) Appl. No.: **19/177,150**

(57) **ABSTRACT**

(22) Filed: **Apr. 11, 2025**

**Related U.S. Application Data**

(63) Continuation of application No. PCT/KR2023/015773, filed on Oct. 12, 2023.

An electronic device may include: at least one grip sensor; at least one processor comprising processing circuitry; a first housing; a second housing coupled to the first housing to be movable along a first direction in which the first housing is configured to be withdrawn or a second direction opposite to the first direction; and a first conductive portion, a second conductive portion, and a third conductive portion, which are disposed on one surface, oriented in the second direction, of the second housing.

**(30) Foreign Application Priority Data**

Oct. 12, 2022 (KR) ..... 10-2022-0131005  
 Nov. 28, 2022 (KR) ..... 10-2022-0162066

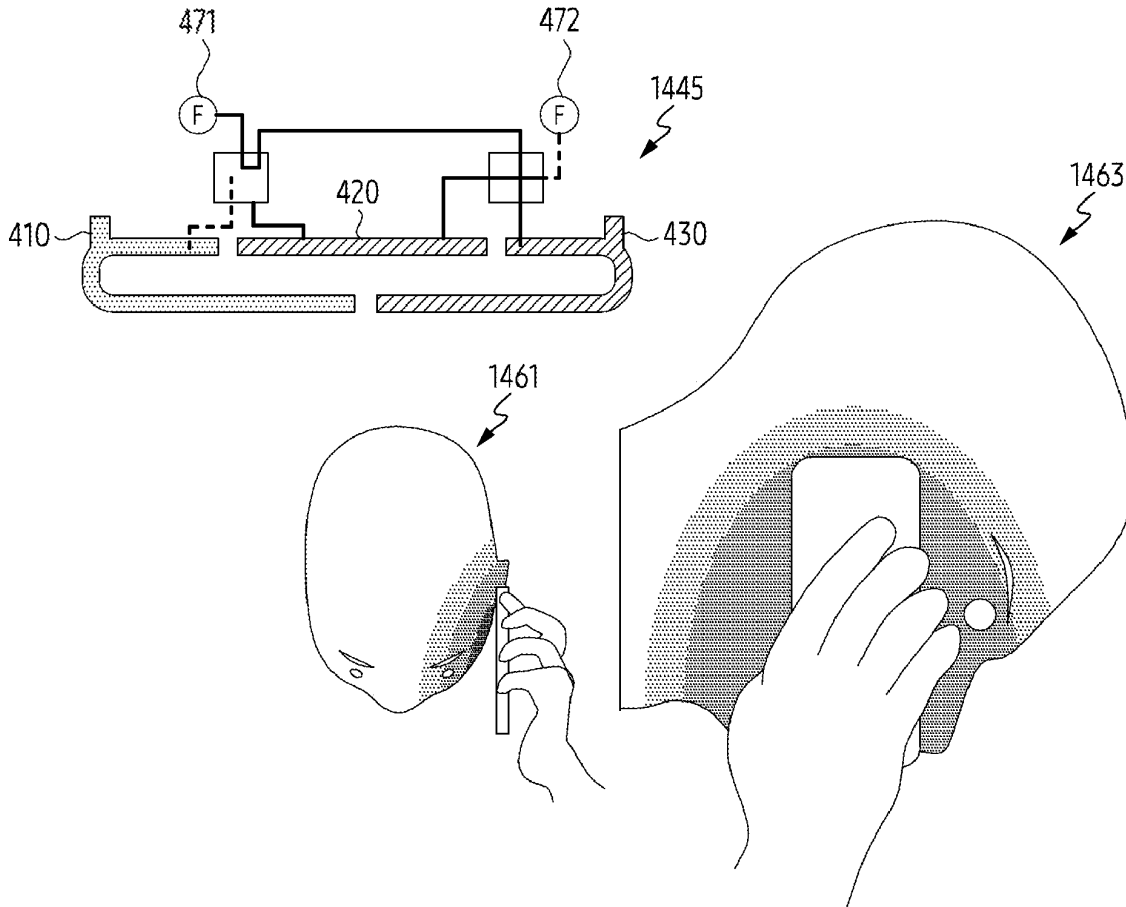



US 20250246795A1

(19) **United States**

(12) **Patent Application Publication**  
**SONG et al.**

(10) **Pub. No.: US 2025/0246795 A1**

(43) **Pub. Date: Jul. 31, 2025**

(54) **ANTENNA STRUCTURE FOR NEAR FIELD COMMUNICATION, AND ELECTRONIC DEVICE COMPRISING SAME**

(71) Applicant: **SAMSUNG ELECTRONICS CO., LTD.**, Suwon-si (KR)

(72) Inventors: **Keumsu SONG**, Suwon-si (KR);  
**Sumin YUN**, Suwon-si (KR)

(73) Assignee: **SAMSUNG ELECTRONICS CO., LTD.**, Suwon-si (KR)

(21) Appl. No.: **19/183,072**

(22) Filed: **Apr. 18, 2025**

**Related U.S. Application Data**

(63) Continuation of application No. PCT/KR2023/015774, filed on Oct. 12, 2023.

**Foreign Application Priority Data**

Oct. 18, 2022 (KR) ..... 10-2022-0134507  
Nov. 25, 2022 (KR) ..... 10-2022-0160968

**Publication Classification**

(51) **Int. Cl.**  
**H01Q 1/22** (2006.01)  
**H01Q 9/04** (2006.01)  
(52) **U.S. Cl.**  
CPC ..... **H01Q 1/22** (2013.01); **H01Q 9/0421** (2013.01)

(57) **ABSTRACT**

An electronic device includes: a metal frame; a circuit board; and a near field communication (NFC) communication circuit on the circuit board; wherein the metal frame includes a conductive portion, a first connection portion formed from the conductive portion, a second connection portion formed from the conductive portion, and a ground portion formed from the conductive portion, wherein the ground portion is between the first connection portion and the second connection portion, wherein the first connection portion is electrically connected to the NFC communication circuit, wherein the second connection portion is electrically connected to the NFC communication circuit, and wherein a positive signal is fed to the first connection portion and a negative signal is fed to the second connection portion.

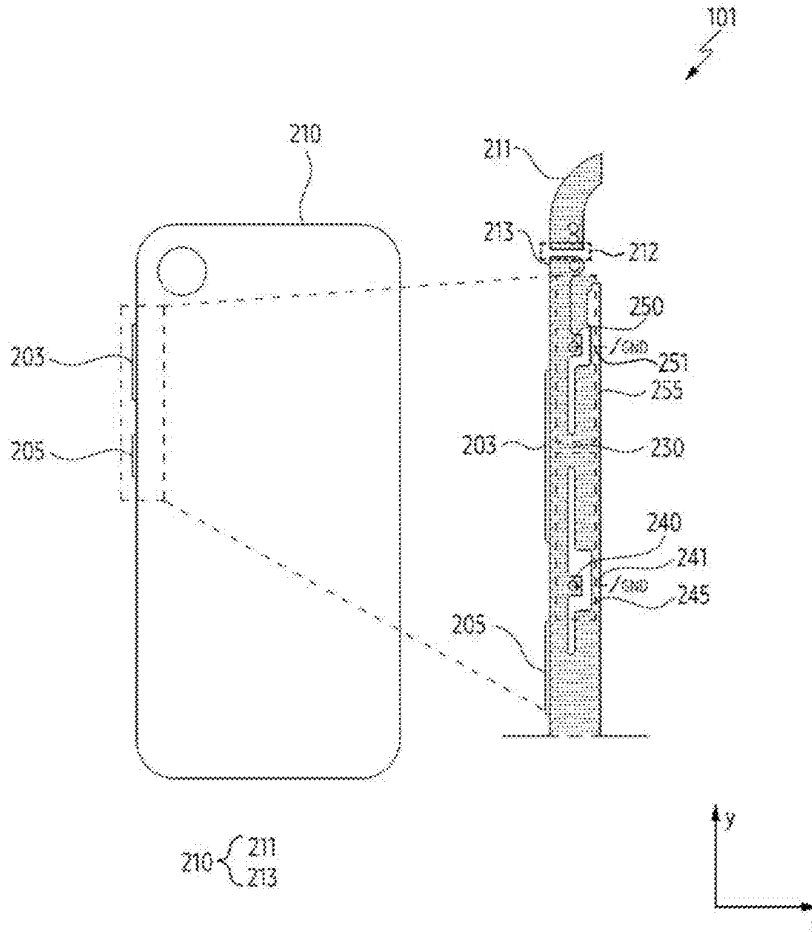



US 20250246808A1

(19) **United States**

(12) **Patent Application Publication**  
**CHANG et al.**

(10) **Pub. No.: US 2025/0246808 A1**

(43) **Pub. Date: Jul. 31, 2025**

(54) **ANTENNA MODULE AND WIRELESS COMMUNICATION DEVICE**

(52) **U.S. Cl.**  
CPC ..... **H01Q 3/36** (2013.01); **H01Q 1/288** (2013.01)

(71) Applicant: **Chiun Mai Communication Systems, Inc.**, New Taipei (TW)

(72) Inventors: **LUNG-TA CHANG**, New Taipei (TW); **CHIA-HSIEN CHEN**, New Taipei (TW); **SHU-WEI JHANG**, New Taipei (TW); **CHE-CHENG KAO**, New Taipei (TW)

(57) **ABSTRACT**

An antenna module and a wireless communication device for a low earth orbit satellite system are provided, including an antenna array and a phase shifter array. The antenna array includes a plurality of groups of antenna units, each of the plurality of groups of antenna units includes N antenna units. The phase shifter array includes a plurality of groups of phase shifters, each of the plurality of groups of phase shifters includes N phase shifters arranged corresponding to the N antenna units, the N phase shifters comprises a first phase shifter, a  $N^{th}$  phase shifter, and N-2 intermediate phase shifters arranged between the first phase shifter and the  $N^{th}$  phase shifter, a phase of an input signal of each of the N phase shifters to the corresponding antenna unit is a multiple of a minimum unit input phase of the phase shifter, wherein N is a positive integer greater than or equal to 3, and the multiple is 0 or any integer.

(21) Appl. No.: **19/032,591**

(22) Filed: **Jan. 21, 2025**

(30) **Foreign Application Priority Data**

Jan. 31, 2024 (TW) ..... 113103854

**Publication Classification**

(51) **Int. Cl.**  
**H01Q 3/36** (2006.01)  
**H01Q 1/28** (2006.01)

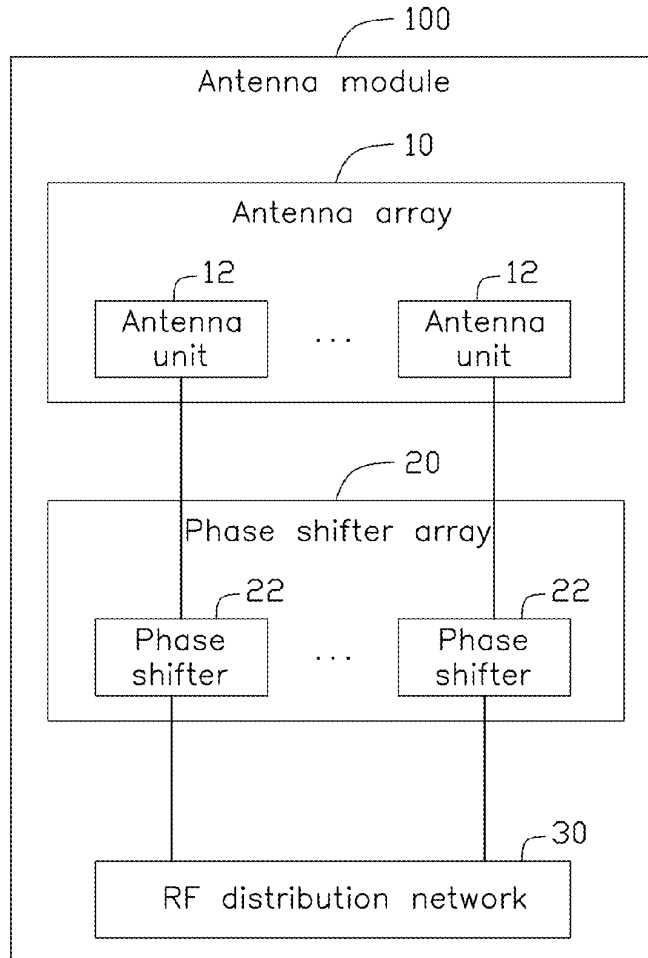



US 20250246810A1

(19) **United States**

(12) **Patent Application Publication**  
**TAI et al.**

(10) **Pub. No.: US 2025/0246810 A1**

(43) **Pub. Date: Jul. 31, 2025**

(54) **HYBRID ANTENNA STRUCTURE**

*H01Q 1/48* (2006.01)

*H01Q 13/10* (2006.01)

(71) Applicant: **Wistron NeWeb Corp.**, Hsinchu (TW)

(52) **U.S. Cl.**

CPC ..... *H01Q 5/20* (2015.01); *H01Q 1/38* (2013.01); *H01Q 1/48* (2013.01); *H01Q 13/106* (2013.01)

(72) Inventors: **Chih-Feng TAI**, Hsinchu (TW);  
**Kuei-Cheng WANG**, Hsinchu (TW);  
**De-Shao YAO**, Hsinchu (TW); **I-Jen WANG**, Hsinchu (TW)

(57) **ABSTRACT**

A hybrid antenna structure includes a dielectric substrate, a metal element, a ground element, a feeding radiation element, and a proximity sensor. The dielectric substrate has a first surface and a second surface which are opposite to each other. The metal element is disposed on the second surface of the dielectric substrate. The metal element has a slot. The ground element is disposed on the first surface of the dielectric substrate. The feeding radiation element is disposed on the first surface of the dielectric substrate. The feeding radiation element is coupled to a feeding point. The feeding radiation element is adjacent to the slot of the metal element. The proximity sensor is coupled to the metal element, such that the metal element is configured as the sensing pad of the proximity sensor.

(21) Appl. No.: **18/607,865**

(22) Filed: **Mar. 18, 2024**

(30) **Foreign Application Priority Data**

Jan. 29, 2024 (TW) ..... 113103315

**Publication Classification**

(51) **Int. Cl.**  
*H01Q 5/20* (2015.01)  
*H01Q 1/38* (2006.01)

100

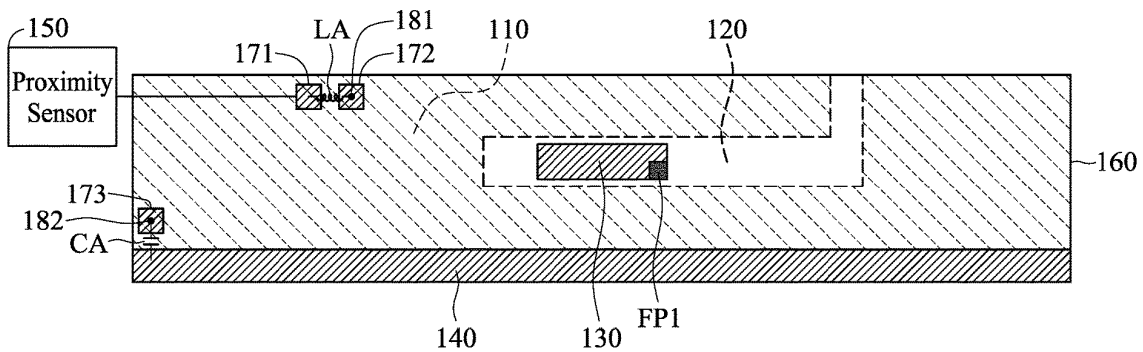



US 20250246811A1

(19) **United States**

(12) **Patent Application Publication**  
**YANG**

(10) **Pub. No.: US 2025/0246811 A1**

(43) **Pub. Date: Jul. 31, 2025**

(54) **ELECTRONIC DEVICE**

(71) Applicant: **Lenovo (Beijing) Limited**, Beijing (CN)

(72) Inventor: **Shirong YANG**, Beijing (CN)

(21) Appl. No.: **19/033,382**

(22) Filed: **Jan. 21, 2025**

(30) **Foreign Application Priority Data**

Jan. 31, 2024 (CN) ..... 202410140078.7

**Publication Classification**

(51) **Int. Cl.**  
**H01Q 5/335** (2015.01)  
**H01Q 1/24** (2006.01)  
**H01Q 21/06** (2006.01)

(52) **U.S. Cl.**  
CPC ..... **H01Q 5/335** (2015.01); **H01Q 1/243** (2013.01); **H01Q 21/06** (2013.01)

(57) **ABSTRACT**

An electronic device includes a target antenna. The target antenna includes a first radiator, a second radiator, a third radiator, a transceiver, and a plate representing ground. The first radiator includes a feed point. The second radiator includes a first ground point and has a first gap with the first radiator. The third radiator includes a second ground point, is located in the first gap between the second radiator and the first radiator, and divides the first gap into a first slit and a second slit. The transceiver is connected to the feed point. The plate representing ground is connected to the first ground point and the second ground point. The target antenna supports a radio frequency (RF) signal of a first frequency and an RF signal of a second frequency, and the first frequency is different from the second frequency.

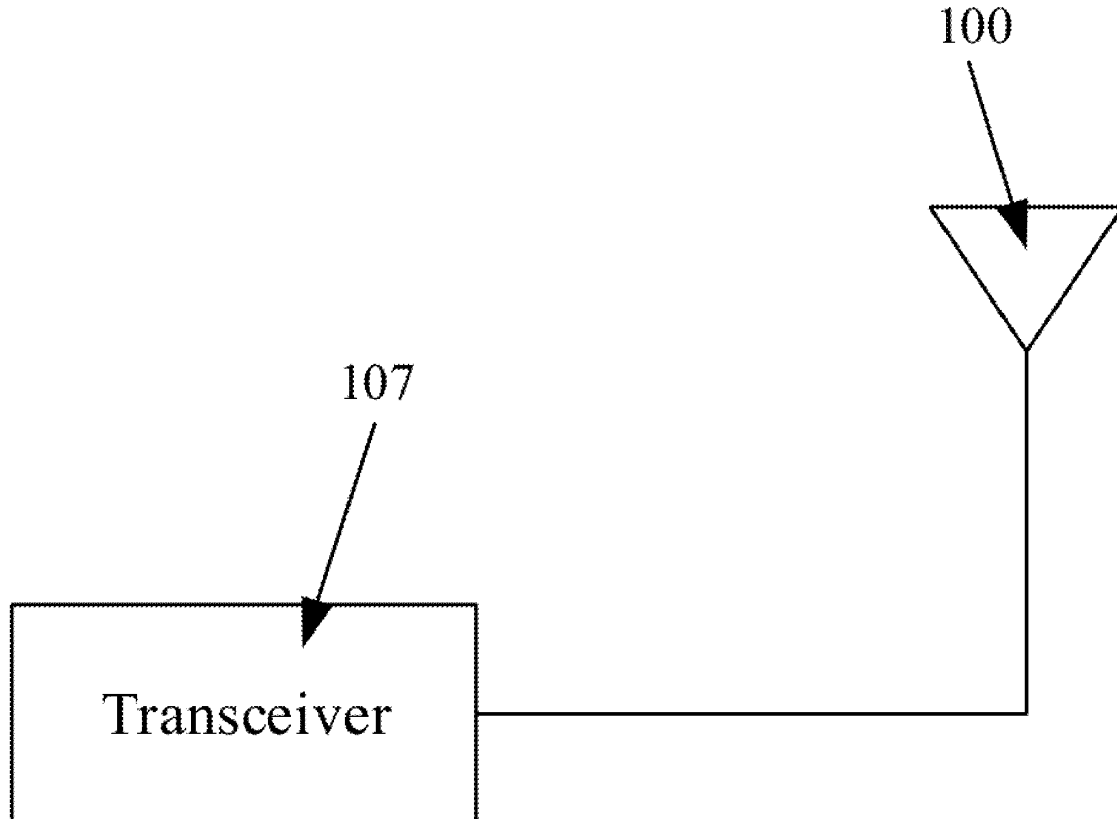



US 20250246814A1

(19) **United States**

(12) **Patent Application Publication**  
**LI et al.**

(10) **Pub. No.: US 2025/0246814 A1**

(43) **Pub. Date: Jul. 31, 2025**

(54) **FEED NETWORK, PHASE SHIFTER, AND ANTENNA APPARATUS**

(71) Applicant: **HUAWEI TECHNOLOGIES CO., LTD.**, Shenzhen (CN)

(72) Inventors: **Chaochao LI**, Xi'an (CN); **Qiqiang GAO**, Dongguan (CN); **Rui GUAN**, Xi'an (CN); **Weimin LI**, Xi'an (CN); **Yongzhan CHEN**, Dongguan (CN)

(73) Assignee: **HUAWEI TECHNOLOGIES CO., LTD.**, Shenzhen, GD (CN)

(21) Appl. No.: **19/185,572**

(22) Filed: **Apr. 22, 2025**

**Related U.S. Application Data**

(63) Continuation of application No. PCT/CN2023/118924, filed on Sep. 14, 2023.

**Foreign Application Priority Data**

Oct. 28, 2022 (CN) ..... 202211337821.5

**Publication Classification**

(51) **Int. Cl.**  
*H01Q 5/50* (2015.01)  
*H01Q 1/24* (2006.01)  
*H01Q 3/36* (2006.01)

(52) **U.S. Cl.**  
CPC ..... *H01Q 5/50* (2015.01); *H01Q 3/36* (2013.01); *H01Q 1/246* (2013.01)

(57) **ABSTRACT**

Embodiments of this application provide a feed network. The feed network includes a housing, and at least one accommodation cavity is disposed in the housing. A transmission structure, a support, and a phase shift medium are disposed in each accommodation cavity. The support is located in the accommodation cavity, and the support is connected to at least one inner wall of the accommodation cavity. In a first direction, the support includes a bearing surface, an inner wall that is of the accommodation cavity and that is opposite to the bearing surface and the bearing surface are spaced apart, and the transmission structure is disposed on a surface of the bearing surface. In the first direction, the phase shift medium is disposed between the transmission structure and one of inner walls of the accommodation cavity, and the phase shift medium is slidably connected to the support in a second direction.

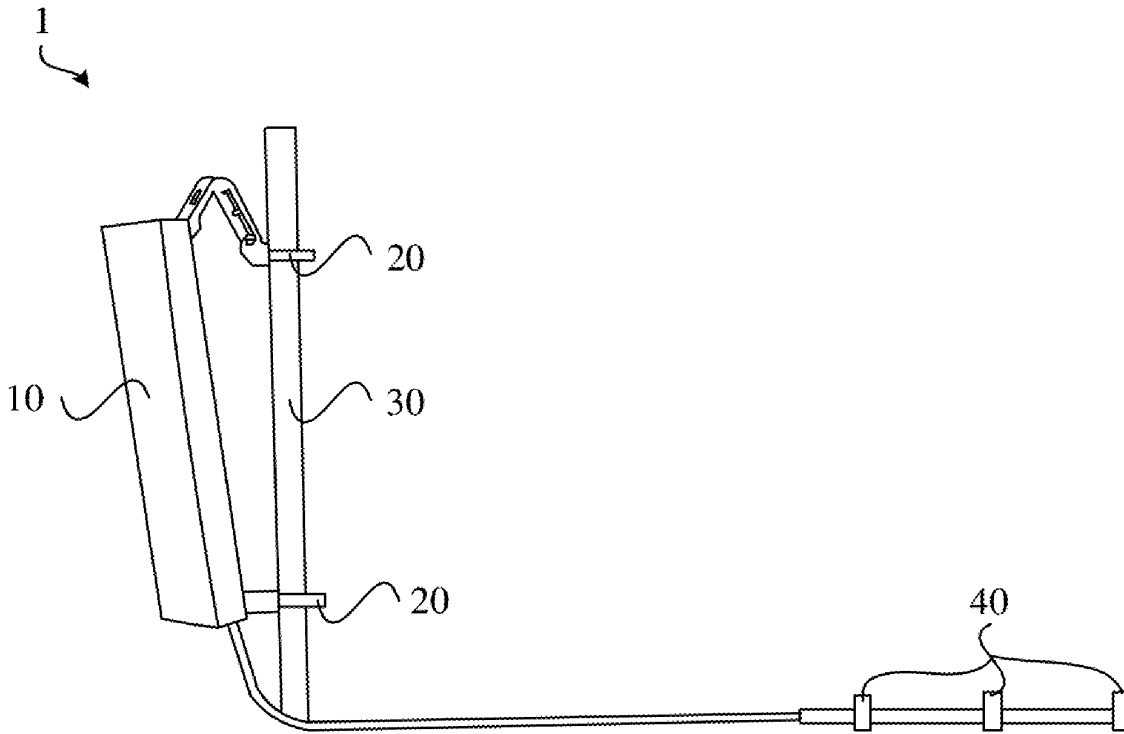



(19) **United States**

(12) **Patent Application Publication**  
**Wu et al.**

(10) **Pub. No.: US 2025/0246816 A1**

(43) **Pub. Date: Jul. 31, 2025**

(54) **ELECTRONIC DEVICE**

**Publication Classification**

- (71) Applicant: **PEGATRON CORPORATION**,  
TAIPEI CITY (TW)
- (72) Inventors: **Chien-Yi Wu**, Taipei City (TW);  
**Shao-Chi Wang**, Taipei City (TW);  
**Hau Yuen Tan**, Taipei City (TW);  
**Chao-Hsu Wu**, Taipei City (TW);  
**Chih-Wei Liao**, Taipei City (TW);  
**Chih-Hung Cho**, Taipei City (TW);  
**Shih-Keng Huang**, Taipei City (TW);  
**Hung-Te Liao**, Taipei City (TW);  
**Ming-Huang Chen**, Taipei City (TW);  
**Chang-Hsun Wu**, Taipei City (TW)

- (51) **Int. Cl.**  
**H01Q 9/04** (2006.01)  
**H01Q 5/335** (2015.01)
- (52) **U.S. Cl.**  
CPC ..... **H01Q 9/0414** (2013.01); **H01Q 5/335**  
(2015.01)

(73) Assignee: **PEGATRON CORPORATION**,  
TAIPEI CITY (TW)

(21) Appl. No.: **18/953,011**

(22) Filed: **Nov. 19, 2024**

(30) **Foreign Application Priority Data**

Jan. 31, 2024 (TW) ..... 113103836

(57) **ABSTRACT**

An electronic device includes a metal back cover, a metal frame, and at least one antenna module. The antenna module includes a separated portion, a first radiator, a second radiator, a third radiator disposed between the first radiator and the second radiator, and a fourth radiator connected to the separated portion. A first section of the first radiator is connected to the separated portion. A second section of the first radiator extends from the first section and has a first ground terminal. A third section of the first radiator extends from the first section and has a second ground terminal. The second radiator extends from the separated portion and has a third ground terminal. The third radiator includes a fourth section and a fifth section extending from the fourth section towards the second radiator. The fourth section is located next to the third section and has a fourth ground terminal.

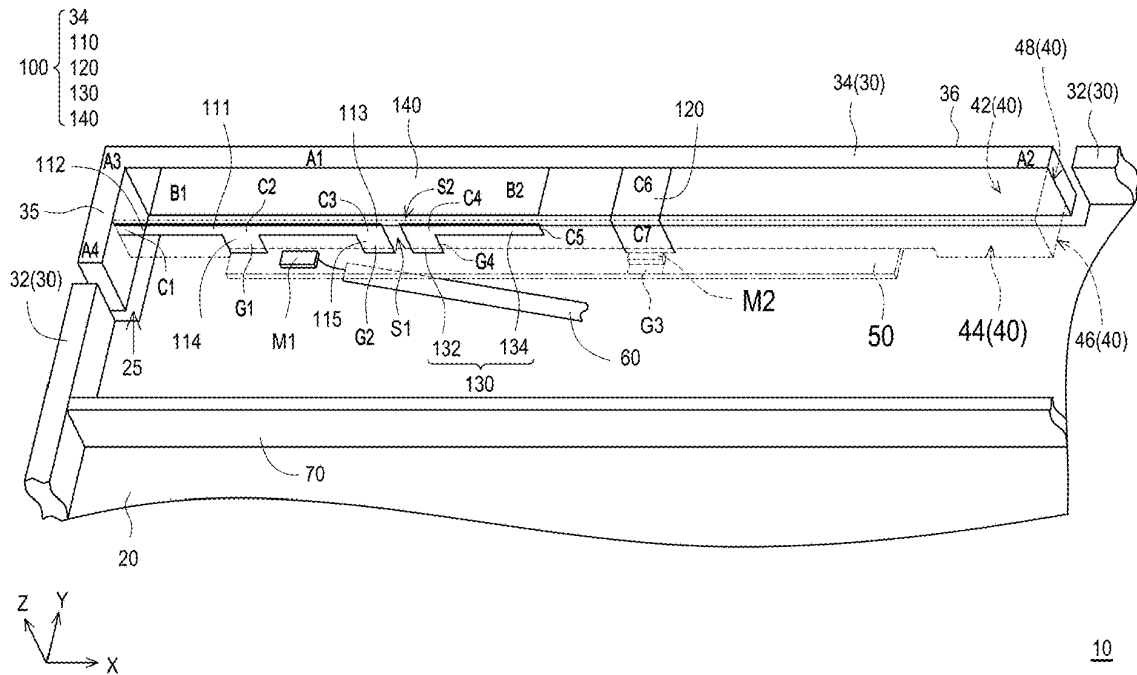



US 20250253529A1

(19) **United States**

(12) **Patent Application Publication** (10) **Pub. No.: US 2025/0253529 A1**  
**KANG et al.** (43) **Pub. Date: Aug. 7, 2025**

(54) **MULTI-PORT ANTENNA FOR DIRECTION FINDING AND METHOD OF MANUFACTURING THE SAME**

(30) **Foreign Application Priority Data**

Feb. 4, 2024 (KR) ..... 10-2024-0019180  
Sep. 12, 2024 (KR) ..... 10-2024-0125106

(71) Applicants: **HONG UNIVERSITY INDUSTRY-ACADEMIA CORPORATION FOUNDATION**, Seoul (KR); **KOOKMIN UNIVERSITY INDUSRTY ACADEMY COOPERATION FOUNDATION**, Seoul (KR)

**Publication Classification**

(51) **Int. Cl.**  
*H01Q 5/307* (2015.01)  
*H01Q 1/38* (2006.01)  
*H01Q 21/00* (2006.01)  
(52) **U.S. Cl.**  
CPC ..... *H01Q 5/307* (2015.01); *H01Q 1/38* (2013.01); *H01Q 21/0037* (2013.01)

(72) Inventors: **Hyunmu KANG**, Seoul (KR); **Jongho Keun**, Seoul (KR); **Sangwoon Youn**, Seoul (KR); **Byung-Jun Jang**, Seoul (KR); **Hosung Choo**, Seoul (KR)

(57) **ABSTRACT**

A single radiator multi-port antenna includes a substrate, a radiator formed on the substrate, three or more ports connected to the radiator and configured to function as feed points for supplying a current to the radiator, and a plurality of vias formed on the substrate or at least one of the ports, wherein the plurality of vias includes at least one of a first via formed at a certain interval from the radiator and a second via formed in the three or more ports.

(21) Appl. No.: **19/047,186**

(22) Filed: **Feb. 6, 2025**

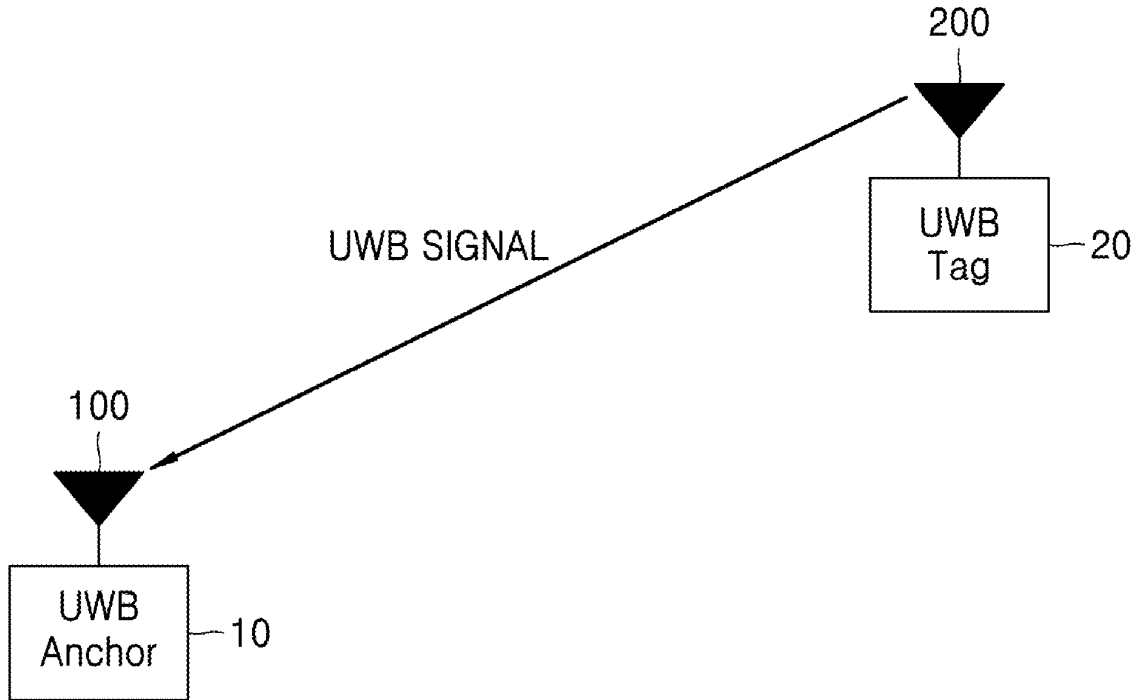



US 20250253530A1

(19) **United States**

(12) **Patent Application Publication** (10) **Pub. No.: US 2025/0253530 A1**

**Guo et al.**

(43) **Pub. Date: Aug. 7, 2025**

(54) **ANTENNA STRUCTURE AND ELECTRONIC DEVICE**

**Publication Classification**

(71) Applicant: **HUAWEI TECHNOLOGIES CO., LTD.**, Shenzhen (CN)

(51) **Int. Cl.**  
*H01Q 5/371* (2015.01)  
*H01Q 5/48* (2015.01)

(72) Inventors: **Jiquan Guo**, Wuhan (CN); **Pengfei Wu**, Shanghai (CN); **Zhaoxuan Liu**, Wuhan (CN); **Jun You**, Wuhan (CN)

(52) **U.S. Cl.**  
CPC ..... *H01Q 5/371* (2015.01); *H01Q 5/48* (2015.01)

(73) Assignee: **HUAWEI TECHNOLOGIES CO., LTD.**, Shenzhen (CN)

(57) **ABSTRACT**

(21) Appl. No.: **19/088,430**

An antenna structure includes a first antenna, a second antenna, and a feeding point. A first radiator and a second radiator of the first antenna are axially symmetrically disposed relative to a perpendicular bisector between a first connection point and a second connection point. The other end of the first radiator and the other end of the second radiator are separately disposed in an extension manner in directions that are away from each other. One end of a second transmission line of the second antenna is electrically connected to the feeding point. The other end of the second transmission line is electrically connected to one end of a third radiator of the second antenna. The other end of the third radiator is grounded.

(22) Filed: **Mar. 24, 2025**

**Related U.S. Application Data**

(63) Continuation of application No. PCT/CN2023/118661, filed on Sep. 13, 2023.

(30) **Foreign Application Priority Data**

Sep. 23, 2022 (CN) ..... 202211166885.3

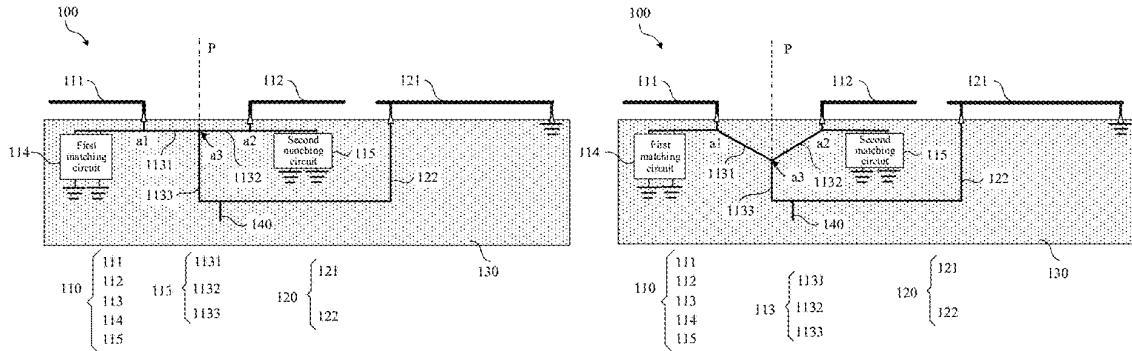



(19) **United States**

(12) **Patent Application Publication**  
**MacGougan et al.**

(10) **Pub. No.: US 2025/0258300 A1**

(43) **Pub. Date: Aug. 14, 2025**

(54) **SYSTEMS AND METHODS FOR SHARED ANTENNA TUNING**

*G01S 19/24* (2010.01)  
*H01Q 1/24* (2006.01)

(71) Applicant: **Apple Inc.**, Cupertino, CA (US)

(52) **U.S. Cl.**  
CPC ..... *G01S 19/235* (2013.01); *G01S 19/20* (2013.01); *G01S 19/24* (2013.01); *H01Q 1/241* (2013.01)

(72) Inventors: **Glenn D. MacGougan**, San Jose, CA (US); **Aditya N. Srivastava**, Fremont, CA (US); **Harsha Shirahatti**, Santa Clara, CA (US); **Madhusudan Chaudhary**, Campbell, CA (US); **Ozgur Ekici**, Ottawa (CA); **Sachin J. Sane**, San Jose, CA (US); **William J. Benetze**, Half Moon Bay, CA (US)

(57) **ABSTRACT**

This disclosure is directed to shared antenna tuning. An electronic device may receive a global navigation satellite system (GNSS) tune request to tune a shared antenna to a GNSS signal frequency. The electronic device may then tune the antenna to the GNSS signal frequency and enable a GNSS receiver. The electronic device may also receive a cellular tune request to tune the antenna to a cellular frequency. The electronic device may tune the antenna to a cellular frequency and may deactivate the GNSS receiver or blank the GNSS receiver. In some embodiments, the electronic device may also communicate with a Low Earth Orbit (LEO) satellite. During LEO satellite communication, the electronic device may transmit a signal to blank a GNSS L1 receiver to avoid signal interference with the LEO satellite communication, and activate a GNSS L5 receiver to receive GNSS signals.

(21) Appl. No.: **19/055,349**

(22) Filed: **Feb. 17, 2025**

**Related U.S. Application Data**

(60) Division of application No. 17/668,828, filed on Feb. 10, 2022, now Pat. No. 12,228,655, which is a continuation of application No. 17/321,171, filed on May 14, 2021, now abandoned.

**Publication Classification**

(51) **Int. Cl.**  
*G01S 19/23* (2010.01)  
*G01S 19/20* (2010.01)

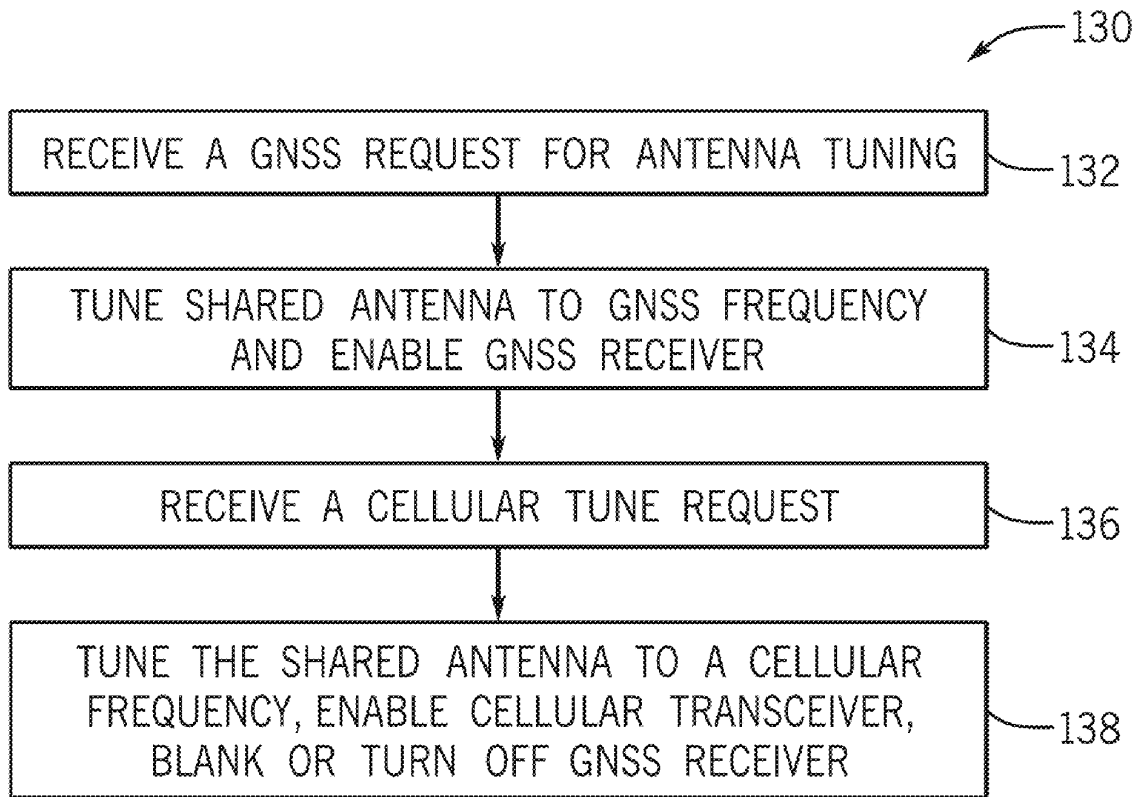



US 20250260169A1

(19) **United States**

(12) **Patent Application Publication**  
**KOMURA**

(10) **Pub. No.: US 2025/0260169 A1**

(43) **Pub. Date: Aug. 14, 2025**

(54) **ANTENNA MODULE AND COMMUNICATION DEVICE EQUIPPED WITH THE SAME**

**Publication Classification**

(51) **Int. Cl.**  
*H01Q 9/04* (2006.01)  
*H01Q 1/22* (2006.01)  
(52) **U.S. Cl.**  
CPC ..... *H01Q 9/045* (2013.01); *H01Q 1/2208* (2013.01); *H01Q 1/2283* (2013.01)

(71) Applicant: **Murata Manufacturing Co., Ltd.**,  
Nagaokakyo-shi (JP)

(72) Inventor: **Ryo KOMURA**, Nagaokakyo-shi (JP)

(73) Assignee: **Murata Manufacturing Co., Ltd.**,  
Nagaokakyo-shi (JP)

(57) **ABSTRACT**

An antenna module includes a dielectric substrate, a ground electrode disposed in the dielectric substrate, flat-plate-shaped radiating elements, feed lines, and a via electrode connected to the ground electrode. The radiating element is disposed opposite the ground electrode in the dielectric substrate. The radiating element is disposed between the radiating element and the ground electrode. The feed line extends through the radiating element and transmits a radio-frequency signal to the radiating element. The feed line transmits a radio-frequency signal to the radiating element. The feed line is electrically coupled to the radiating element at a position offset from a center of the radiating element in a first direction. The feed line is electrically coupled to the radiating element in a second direction different from the first direction.

(21) Appl. No.: **19/191,060**

(22) Filed: **Apr. 28, 2025**

**Related U.S. Application Data**

(63) Continuation of application No. PCT/JP2023/033504, filed on Sep. 14, 2023.

**Foreign Application Priority Data**

Dec. 2, 2022 (JP) ..... 2022-193790

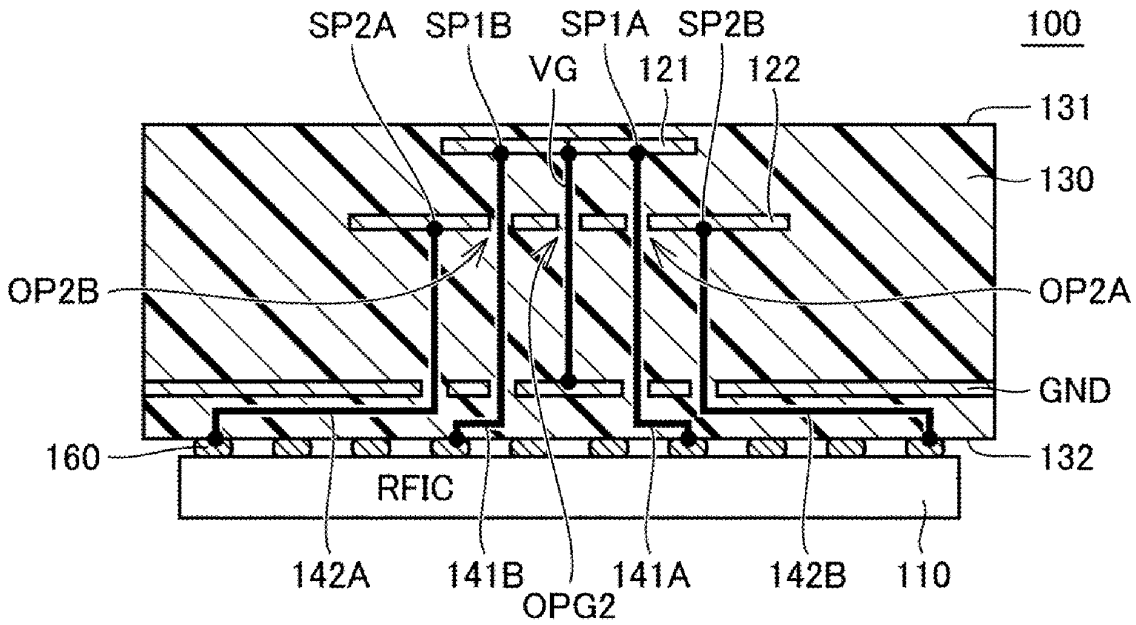



US 20250260175A1

(19) **United States**

(12) **Patent Application Publication**  
**YANG**

(10) **Pub. No.: US 2025/0260175 A1**

(43) **Pub. Date: Aug. 14, 2025**

(54) **ANTENNA AND ELECTRONIC DEVICE**

(52) **U.S. Cl.**

CPC ..... **H01Q 21/061** (2013.01); **H01Q 1/38** (2013.01)

(71) Applicants: **Beijing BOE Sensor Technology Co., Ltd.**, Beijing (CN); **BOE TECHNOLOGY GROUP CO., LTD.**, Beijing (CN)

(57) **ABSTRACT**

An antenna includes: a first substrate and a second substrate. The first substrate includes: a first dielectric substrate, a first reference electrode layer, a first radiation part, and a feeder group. The first dielectric substrate includes a main substrate and a side substrate, the feeder group includes at least one feeder, in each of which, each feeder is electrically connected to one first radiation part, and different feeders are electrically connected to different first radiation parts. The second substrate includes: a second dielectric substrate, a second reference electrode layer, and a feed structure. The feed structure corresponds to the feeder group, and for corresponding feed structure and feeder group, each first feed port in the feed structure is electrically connected to one feeder in the feeder group through a first connection via which runs through at least the side substrate, the second reference electrode layer, and the second dielectric substrate.

(72) Inventor: **Shuo YANG**, Beijing (CN)

(21) Appl. No.: **18/701,241**

(22) PCT Filed: **Apr. 7, 2023**

(86) PCT No.: **PCT/CN2023/086960**

§ 371 (c)(1),

(2) Date: **Apr. 14, 2024**

**Publication Classification**

(51) **Int. Cl.**

**H01Q 21/06** (2006.01)

**H01Q 1/38** (2006.01)

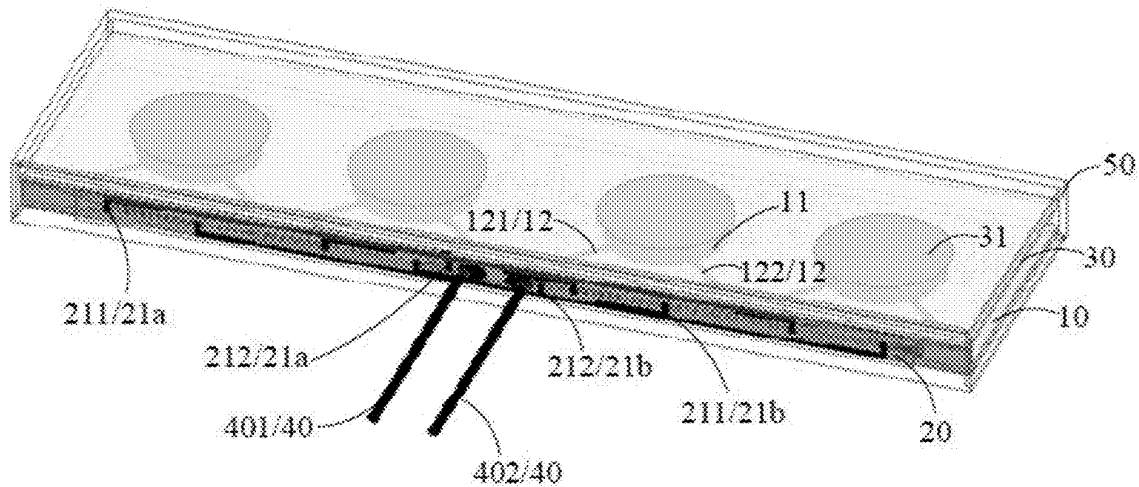



US 20250260176A1

(19) **United States**

(12) **Patent Application Publication**  
**BIGONGIARI et al.**

(10) **Pub. No.: US 2025/0260176 A1**

(43) **Pub. Date: Aug. 14, 2025**

(54) **ANTENNA ARRAY SYSTEM**

(52) **U.S. Cl.**

(71) Applicant: **Telefonaktiebolaget LM Ericsson (PUBL)**, Stockholm (SE)

CPC ..... **H01Q 21/061** (2013.01); **H05K 1/0243** (2013.01); **H05K 1/0274** (2013.01); **H05K 2201/10098** (2013.01)

(72) Inventors: **Alessandra BIGONGIARI**, Pisa (IT);  
**Antonio D'ERRICO**, Pisa (IT);  
**Ingmar ANDERSSON**, Göteborg (SE);  
**Lars MANHOLM**, Göteborg (SE)

(57) **ABSTRACT**

(21) Appl. No.: **18/857,688**

The disclosure provides an antenna array system, comprising: a printed circuit board; one or more radio-frequency circuits arranged on a surface of the printed circuit board; a plurality of optical-to-electrical converters electrically coupled to the one or more radio-frequency circuits; and an optical distribution layer arranged over the plurality of optical-to-electrical converters, for distributing one or more optical signals to the plurality of optical-to-electrical converters. The one or more radio-frequency circuits comprise an array of radiating antenna elements, and the optical distribution layer is arranged over a part of the surface of the printed circuit board such that the optical distribution layer does not cover the array of radiating antenna elements.

(22) PCT Filed: **Apr. 20, 2022**

(86) PCT No.: **PCT/EP2022/060461**

§ 371 (c)(1),

(2) Date: **Oct. 17, 2024**

**Publication Classification**

(51) **Int. Cl.**  
**H01Q 21/06** (2006.01)  
**H05K 1/02** (2006.01)

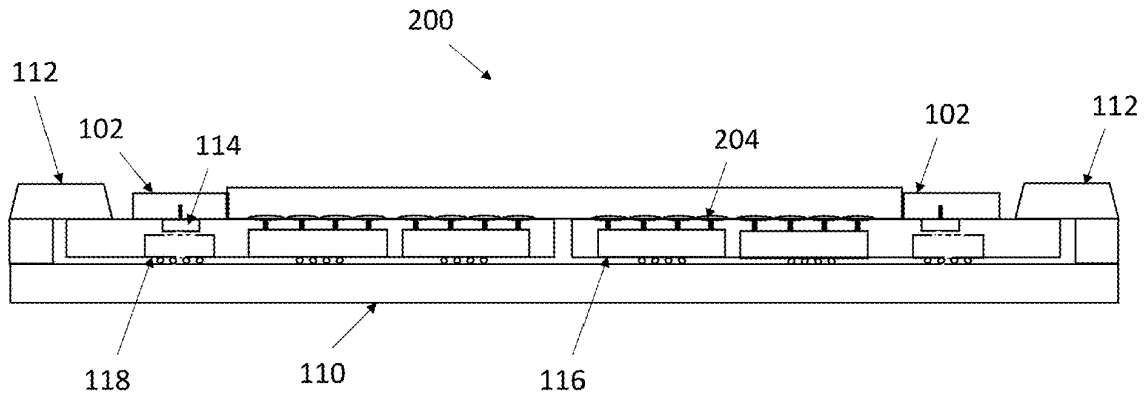



US 20250260423A1

(19) **United States**

(12) **Patent Application Publication**  
**MORI et al.**

(10) **Pub. No.: US 2025/0260423 A1**

(43) **Pub. Date: Aug. 14, 2025**

(54) **RADIO FREQUENCY CIRCUIT**

**Publication Classification**

(71) Applicant: **Murata Manufacturing Co., Ltd.**,  
Nagaokakyo-shi (JP)

(51) **Int. Cl.**  
**H04B 1/00** (2006.01)  
**H04B 1/04** (2006.01)

(72) Inventors: **Hirotsugu MORI**, Nagaokakyo-shi (JP); **Morio TAKEUCHI**,  
Nagaokakyo-shi (JP)

(52) **U.S. Cl.**  
CPC ..... **H04B 1/006** (2013.01); **H04B 1/001**  
(2013.01); **H04B 1/0483** (2013.01)

(73) Assignee: **Murata Manufacturing Co., Ltd.**,  
Nagaokakyo-shi (JP)

(57) **ABSTRACT**

(21) Appl. No.: **19/174,170**

A radio frequency circuit includes: a first filter having a passband that includes a downlink band of a first band and a downlink band of a second band; a second filter having a passband that includes the downlink band of the first band and a downlink band of a third band; and a first switch that includes a first terminal connected to an antenna connection terminal, a second terminal connected to the first filter, and a third terminal connected to the second filter. The downlink band of the first band, the downlink band of the second band, and the downlink band of the third band at least partially overlap one another, and a combination of the first band and the second band and a combination of the first band and the third band are included in predefined band combinations for simultaneous communication.

(22) Filed: **Apr. 9, 2025**

**Related U.S. Application Data**

(63) Continuation of application No. PCT/JP2023/027630, filed on Jul. 27, 2023.

**Foreign Application Priority Data**

Oct. 12, 2022 (JP) ..... 2022-164115

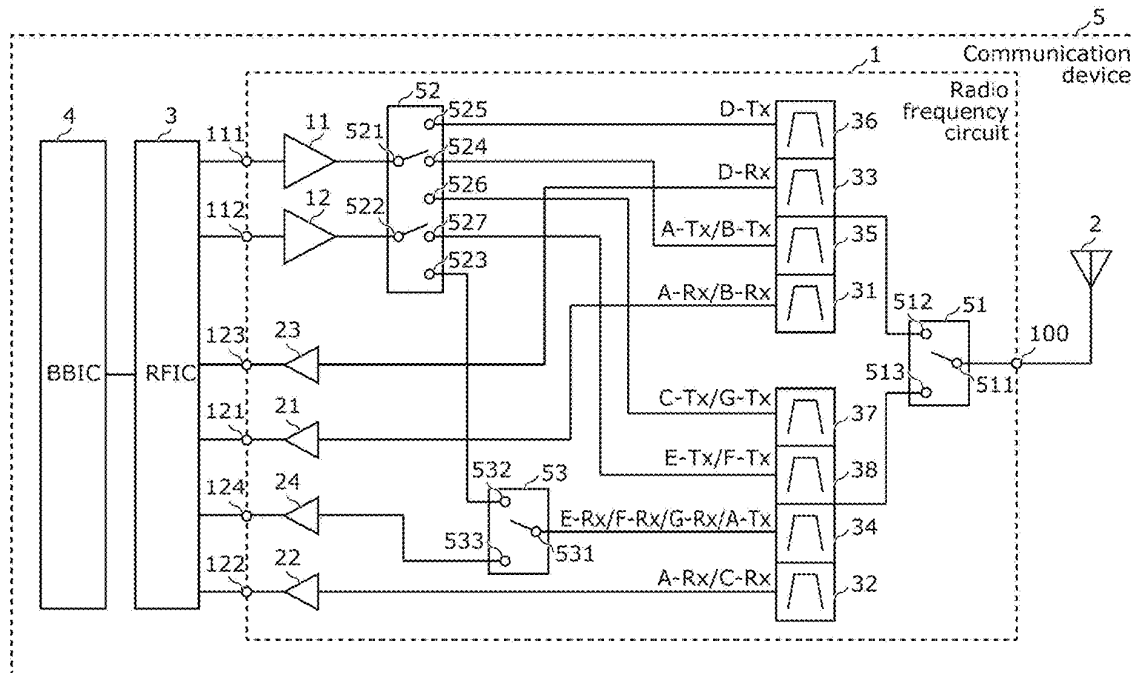



(19) **United States**

(12) **Patent Application Publication**  
**HUANG et al.**

(10) **Pub. No.: US 2025/0260531 A1**

(43) **Pub. Date: Aug. 14, 2025**

(54) **SOUNDING REFERENCE SIGNAL ANTENNA SWITCH WITH THREE TRANSMIT CHAINS**

**Publication Classification**

(71) Applicant: **QUALCOMM Incorporated**, San Diego, CA (US)

(51) **Int. Cl.**  
**H04L 5/00** (2006.01)  
**H04B 7/06** (2006.01)

(72) Inventors: **Yi HUANG**, San Diego, CA (US); **Enoch Shiao-Kuang LU**, San Diego, CA (US); **Muhammad Sayed Khairy ABDELGHAFAR**, San Jose, CA (US); **Peter GAAL**, San Diego, CA (US); **Jae Ho RYU**, San Diego, CA (US)

(52) **U.S. Cl.**  
CPC ..... **H04L 5/0048** (2013.01); **H04B 7/0608** (2013.01); **H04B 7/0628** (2013.01)

(57) **ABSTRACT**

Methods, systems, and devices for wireless communications are described. A user equipment (UE) may receive an indication of a set of sounding occasions that includes resources for sounding a total quantity of antennas using a set of transmit chains of the UE. The UE may transmit one or more sounding reference signals (SRSs) over a first quantity of antenna(s) via a first group of the set of transmit chains, the first quantity of antenna(s) is less than the total quantity of antennas, and the first group is any quantity of the set of transmit chains. The UE may transmit one or more SRSs over a second quantity of antenna(s) via a second group of the set of transmit chains, the second quantity of antenna(s) is less than the total quantity of antennas, and the second group is any quantity of the set of transmit chains.

(21) Appl. No.: **19/051,004**

(22) Filed: **Feb. 11, 2025**

**Related U.S. Application Data**

(60) Provisional application No. 63/553,535, filed on Feb. 14, 2024.

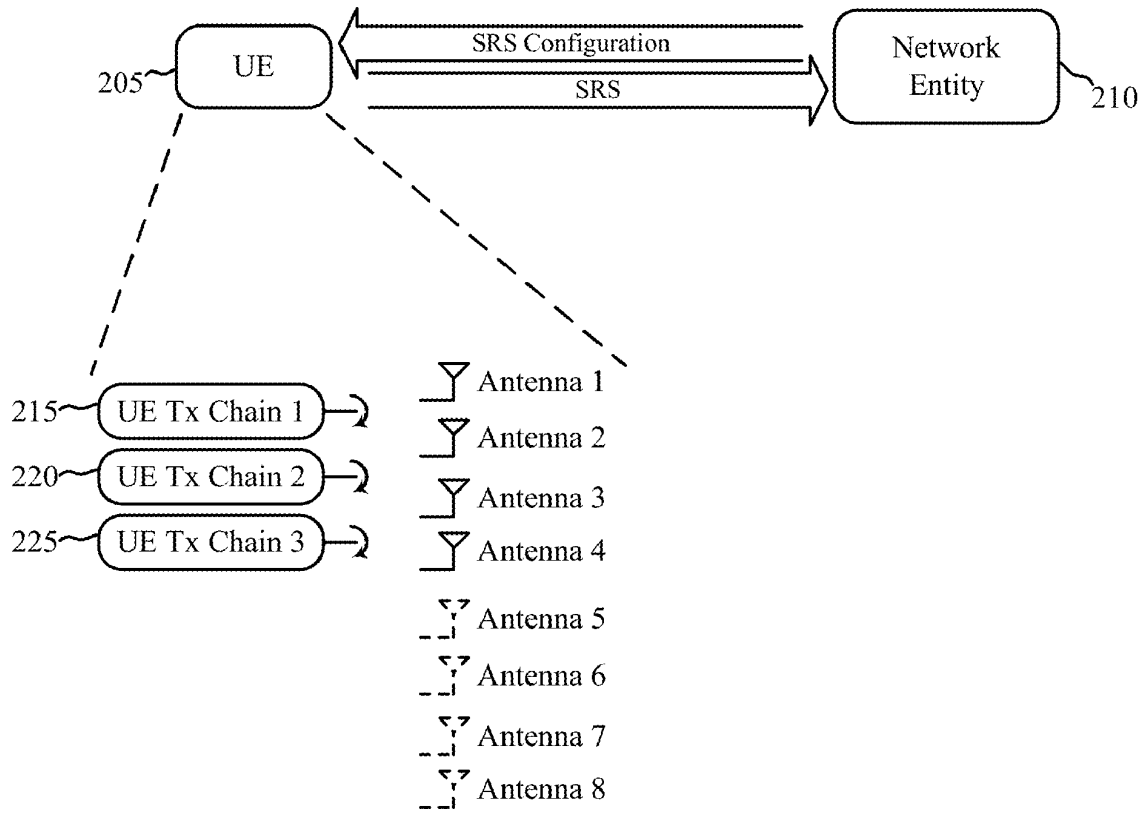



US 20250261308A1

(19) **United States**

(12) **Patent Application Publication**  
**LEE et al.**

(10) **Pub. No.: US 2025/0261308 A1**

(43) **Pub. Date: Aug. 14, 2025**

(54) **CIRCUIT BOARD, ANTENNA STRUCTURE INCLUDING THE SAME AND IMAGE DISPLAY DEVICE INCLUDING THE SAME**

**Publication Classification**

(51) **Int. Cl.**  
*H05K 1/11* (2006.01)  
*H01Q 1/22* (2006.01)  
*H05K 1/02* (2006.01)

(52) **U.S. Cl.**  
 CPC ..... *H05K 1/115* (2013.01); *H01Q 1/2283* (2013.01); *H05K 1/028* (2013.01); *H05K 2201/093* (2013.01); *H05K 2201/10098* (2013.01)

(71) Applicant: **DONGWOO FINE-CHEM CO., LTD.**, Jeollabuk-do (KR)

(72) Inventors: **WON HEE LEE**, Jeollabuk-do (KR);  
**NA YEON KIM**, Jeollabuk-do (KR)

(21) Appl. No.: **19/038,903**

(57) **ABSTRACT**

A circuit board includes a core layer including a wiring portion and a ground portion arranged around the wiring portion, a circuit wiring extending on the wiring portion, a first ground pattern arranged around the circuit wiring and spaced apart from the circuit wiring, and a first via structure arranged in the ground portion to penetrate the core layer. The first via structure is not arranged in the wiring portion.

(22) Filed: **Jan. 28, 2025**

(30) **Foreign Application Priority Data**

Feb. 8, 2024 (KR) ..... 10-2024-0019348

